

**(12) STANDARD PATENT APPLICATION (11) Application No. AU 2010308280 A9**  
**(19) AUSTRALIAN PATENT OFFICE**

(54) Title  
**Metronomic convection enhanced delivery of intrathecal chemotherapy using an im-  
planted magnetic breather pump (MBP) for leptomeningeal carcinomatosis**

(51) International Patent Classification(s)  
**A61F 2/958** (2013.01)                      **A61M 25/088** (2006.01)  
**A61M 1/00** (2006.01)                      **A61M 25/092** (2006.01)  
**A61M 5/142** (2006.01)                      **A61M 31/00** (2006.01)

(21) Application No: **2010308280**                      (22) Date of Filing: **2010.10.19**

(87) WIPO No: **WO11/049920**

(30) Priority Data

(31) Number	(32) Date	(33) Country
<b>12/581,756</b>	<b>2009.10.19</b>	<b>US</b>

(43) Publication Date: **2011.04.28**

(48) Corrigenda Journal Date: **2015.10.01**

(71) Applicant(s)  
**Leslie Farkas;Laszlo Farkas;Bruce Marx;Pharmaco-Kinesis Corporation;David  
Johnson;Thomas Chen;Yehoshua Shachar**

(72) Inventor(s)  
**Shachar, Yehoshua;Chen, Thomas;Farkas, Leslie;Marx, Bruce;Johnson,  
David;Farkas, Laszlo**

(74) Agent / Attorney  
**Pizzeys Patent and Trade Mark Attorneys, GPO Box 1374, BRISBANE, QLD, 4001**

(56) Related Art  
**US 4378797 A**  
**US 2007/0135765 A1**  
**US 2008/0064966 A1**  
**US 4610658 A**  
**US 5429582 A**  
**US 4360019 A**  
**US 2004/0092577 A1**

REVISED VERSION

(19) World Intellectual Property Organization  
International Bureau



(43) International Publication Date  
28 April 2011 (28.04.2011)

(10) International Publication Number  
**WO 2011/049920 A9**

PCT

(51) International Patent Classification:

*A61M 25/10* (2006.01)    *A61M 31/00* (2006.01)  
*A61M 25/088* (2006.01)    *A61M 1/00* (2006.01)  
*A61M 25/092* (2006.01)    *A61M 5/142* (2006.01)

(21) International Application Number:

PCT/US2010/053146

(22) International Filing Date:

19 October 2010 (19.10.2010)

(25) Filing Language:

English

(26) Publication Language:

English

(30) Priority Data:

12/581,756    19 October 2009 (19.10.2009)    US

(71) Applicant (for all designated States except US): **PHARMACO-KINESIS CORPORATION** [US/US]; 10524 S. La Cienega Blvd., Inglewood, California 90304 (US).

(72) Inventors; and

(71) Applicants : **SHACHAR, Yehoshua** [US/US]; 2417 22nd Street, Santa Monica, California 90405 (US). **CHEN, Thomas** [US/US]; 5155 La Canada, La Canada, California 91011 (US). **FARKAS, Leslie** [US/US]; 254 N. Amaz St., Ojai, California 93023 (US). **MARX, Bruce** [US/US]; 1233 Avila Drive, Ojai, California 93023 (US). **JOHNSON, David** [US/US]; 8450 Delongpre Ave #5, West Hollywood, California 90069 (US). **FARKAS, Laszlo** [US/US]; 29 Taormina Ave, Ojai, California 93023 (US).

(74) Agents: **DAWES, Marcus et al.**; 5200 Warner Ave, Ste 106, Huntington Beach, California 92649 (US).

(81) Designated States (unless otherwise indicated, for every kind of national protection available):

AE, AG, AL, AM, AO, AT, AU, AZ, BA, BB, BG, BH, BR, BW, BY, BZ, CA, CH, CL, CN, CO, CR, CU, CZ, DE, DK, DM, DO, DZ, EC, EE, EG, ES, FI, GB, GD, GE, GH, GM, GT, HN, HR, HU, ID, IL, IN, IS, JP, KE, KG, KM, KN, KP, KR, KZ, LA, LC, LK, LR, LS, LT, LU, LY, MA, MD, ME, MG, MK, MN, MW, MX, MY, MZ, NA, NG, NI, NO, NZ, OM, PE, PG, PH, PL, PT, RO, RS, RU, SC, SD, SE, SG, SK, SL, SM, ST, SV, SY, TH, TJ, TM, TN, TR, TT, TZ, UA, UG, US, UZ, VC, VN, ZA, ZM, ZW.

(84) Designated States (unless otherwise indicated, for every kind of regional protection available):

ARIPO (BW, GH, GM, KE, LR, LS, MW, MZ, NA, SD, SL, SZ, TZ, UG, ZM, ZW), Eurasian (AM, AZ, BY, KG, KZ, MD, RU, TJ, TM), European (AL, AT, BE, BG, CH, CY, CZ, DE, DK, EE, ES, FI, FR, GB, GR, HR, HU, IE, IS, IT, LT, LU, LV, MC, MK, MT, NL, NO, PL, PT, RO, RS, SE, SI, SK, SM, TR), OAPI (BF, BJ, CF, CG, CI, CM, GA, GN, GQ, GW, ML, MR, NE, SN, TD, TG).

Published:

— with declaration under Article 17(2)(a); without abstract; title not checked by the International Searching Authority

(48) Date of publication of this revised version:

9 September 2011

(15) Information about Correction:

see Notice of 9 September 2011

(54) Title: METRONOMIC CONVECTION ENHANCED DELIVERY OF INTRATHECAL CHEMOTHERAPY USING AN IMPLANTED MAGNETIC BREATHING PUMP (MBP) FOR LEPTOMENINGEAL CARCINOMATOSIS

(57) Abstract:



WO 2011/049920 A9

**METRONOMIC CONVECTION ENHANCED DELIVERY OF INTRATHECAL  
CHEMOTHERAPY USING AN IMPLANTED MAGNETIC BREATHING PUMP (MBP)  
FOR LEPTOMENINGEAL CARCINOMATOSIS**

**[01] Background of the Invention**

**[02]** *Field of the Invention*

**[03]** The invention relates to the field of implantable drug delivery systems, specifically a magnetically controlled aspirating pump and a method for delivering metronomic intrathecal chemotherapy into the spinal fluid of a patient using the same.

**[04]** *Description of the Prior Art*

**[05]** When tumors develop inside the human body, the options for available treatment are fairly narrow. This is even more so when the tumor develops inside a vital organ such as the brain or spinal cord. Diseases such as leptomeningeal carcinomatosis that develop in or around the leptomeninges of the brain and spinal cord are notoriously difficult to treat and thus have a high mortality rate.

**[06]** Leptomeningeal carcinomatosis is caused by metastatic seeding of the leptomeninges from systemic cancer, usually breast, lung, and melanoma. If left untreated, patients typically die within two months of diagnosis. Traditionally, the options for treating leptomeningeal carcinomatosis in or around the spinal cord include radiation, chemotherapy, and local intrathecal or intraventricular chemotherapy. Each of these prior methods of treating leptomeningeal carcinomatosis have had some form of success in the past, however each of them also contain various deficiencies and

pitfalls that make them less than ideal when treating a patient. What is needed is a more reliable, easier, and effective process for treating leptomeningeal carcinomatosis.

[07] Radiation is a common mode of treatment for leptomeningeal carcinomatosis. It is usually given as a fractionated dosage treatment, covering a certain field encompassing the spinal column, over a period of six weeks. Spatially localized forms of radiation, including cyberknife and gamma knife have been used with varying levels of success at focal areas of leptomeningeal enhancement. Although radiation is still widely acknowledged as the one of the most effective modes of adjunctive treatment, it suffers from the disadvantage of limited fractions and applications.

[08] Another method used to combat brain tumors is systemic chemotherapy. Systemic chemotherapy is a viable option as an adjunct to radiation. However, it is limited in efficacy in metastatic seeding the spinal column by: 1) delivery across the blood brain/spine barrier, 2) development of drug resistance by the cancer cells, and 3) systemic side-effects from the chemotherapeutic agent. Because the blood brain/spine barrier is only partially broken down in the presence of leptomeningeal carcinomatosis, it still impairs the effective delivery and transport of systemic chemotherapy into the spinal fluid. Lastly, chemotherapy is distributed systemically throughout the entire body. Because the whole body of the patient undergoes the treatment (not just the spinal related area), undesirable side effects such as nausea, diarrhea, hair loss, and loss of appetite and energy may occur. Some of the side effects are so strong in some patients that chemotherapy is unavailable to them as a treatment and thus decrease their overall chances for survival.

**[009]** In fact, even with radiation and systemic chemotherapy, the median survival of a patient with leptomeningeal carcinomatosis is currently only approximately six months.

**[010]** Recently, intrathecal chemotherapy using either DepoCyt, a long acting liposomal Ara-C and produced by Enzon Pharmaceuticals of Japan, or methotrexate has been used with a mild degree of success. Most patients are treated with interval injections of chemotherapy via an Ommaya reservoir or via a lumbar puncture. Inevitably the tumor recurs despite treatment. Consequently, the patients may develop hydrocephalus, and eventually death.

**[011]** The underlying hypothesis of using polypharmacy employed by the current invention is based on the premise that combination treatment is better than monotherapy. Moreover, the concept of controlling the delivery of the polypharmacy in a controlled metronomic methodology is advocated as a method of better control. Thus, a first step in administering a cytotoxic agent is to determine the maximum tolerated dose (MTD). However, when used in traditional treatment methods, such as chemotherapy, the cytotoxic agents are delivered to the patient in a manner that allows the cytotoxic agents to be distributed more or less globally throughout the body of the patient. Relatively large doses of the drugs are required since only a small fraction of the administered dose will be present at the desired site at any given time. The remainder of the dose will be in the other parts of body. Moreover, a major problem with conventional chemotherapy is lack of specificity in targeting the cancer cell.

**[012]** The use of large doses of toxic agents often leads to serious and debilitating side effects. Moreover, the global administration of drugs is often not

compatible with combination therapies where a number of medicating agents are used synergistically to treat tumors or other conditions. Thus, the global administration of medicating agents to treat tumors and other such medical conditions is an inefficient and often dangerous technique that often leads to severe or debilitating side effects.

**[013]** Recently, there have been some developments in the field of medical drug delivery systems. The majority of these systems have taken the form of a pump or other device that releases a variety of drugs into various positions in and around the body of a patient.

**[014]** For example, many of the devices found in the prior art are much like the inventions disclosed in U.S. Patents 6,852,104 ("Blonquist") and 6,659,978 ("Kasuga"). Both of these inventions comprise a small tank for holding a drug regimen, a pump for pumping the drug regimen into the body of a patient, and some sort of electronic control system that allows the user to program the specific amount and at what time a certain drug regimen is to be administered. While these apparatuses may be ideal for administering certain drugs such as insulin to patients who are diabetic, they are neither designed nor suitable for directly treating leptomeningeal carcinomatosis within the brain and spinal cord of a patient.

**[015]** Other prior art examples such as U.S. Patents 5,242,406 ("Gross") and 6,571,125 ("Thompson") offer smaller, more convenient alternatives for administering drugs, however their reliance on maintaining a specific set of pressures and a certain amount of electrical current respectively makes them too complicated and prone to error.

**[016]** U.S. Patents 7,351,239 ("Gill"), 7,288,085 ("Olsen"), and 6,726,678 ("Nelson") disclose a pump or reservoir that is capable of delivering medicating fluids to the brain, but requires that the pump and drug reservoir be implanted in different locations within the patient. This configuration is not only uncomfortable for the patient, but also increases the possibility of infection and unnecessarily complicates the implanting procedure. Additionally, every time the patient needs the drug reservoir refilled or the pump battery replaced, the physician must invasively re-enter the patient. Finally, none these prior methods disclose a way of measuring the value of the vascular endothelial growth factor (VEGF) so as to enable tailoring of the delivered medical agent, toxicity to meet the needs of a specific individual patient.

**[017]** What is needed is a device and a method that is capable of delivering medicating agents directly to the cerebrospinal fluid (CSF) of the brain and spinal cord that is easy to operate and relatively simple to implant, while at the same time, is easy to maintain throughout the patient's treatment cycle and customize to the patient's specific needs without causing all of the negative side effects associated with previous treatment methods.

#### **[018] Brief Summary of the Invention**

**[019]** A magnetically controlled pump is implanted into the cerebrospinal fluid (CSF) of a patient and delivers a dose of therapeutic agent at a controlled rate corresponding to the specific needs of the patient for leptomeningeal carcinomatosis.

**[020]** The illustrated embodiment of the invention solves the above limitations in the prior art and other problems by effectively treating leptomeningeal carcinomatosis

using a multi-delivery catheter implanted into the CSF. Through at least two proximal ports, an internalized externally controlled pump will deliver up to four different kinds of chemotherapeutic agents at a controlled rate corresponding to the specific needs of the patient. Spinal fluid drawn from the patient is analyzed. The operation of the apparatus and hence the treatment is remotely controlled based on these measurements and displayed through an external controller.

**[021]** The microdelivery pump has three components: a proximal head reservoir, a catheter extending from the proximal head, and an analyzer unit connected to the catheter. The proximal head is comprised of a catheter inserted into the CSF, the illustrated embodiment of the invention comprises a proximal delivery device which will be implanted into the lateral ventricle of the frontal horn or intrathecally. The head cap of the pouch also contains a valve that allows the reservoir of the apparatus to be refilled and for cerebrospinal fluid that has been drawn into the pouch to be withdrawn from the spinal region of the patient via a suction nozzle. In this way, the pump also enables a decompressive mechanism for controlling the intratumoral pressure, and for sampling fluid.

**[022]** An embodiment of the current invention involves a multidelivery catheter. Conventional catheters used for convection enhanced delivery for tumors caused by leptomeningeal carcinomatosis consist of either a single port in the tip of peritoneal tubing used for ventriculoperitoneal shunts, or a proximal shunt catheter with multiple holes cut within 1 cm of the tip of catheter tip.

**[023]** The medication intake line and the cerebrospinal fluid return line coupled to the head cap of the apparatus are housed within a silicone catheter. The catheter



runs underneath the skin of the patient, in the posterior auricular location to the neck, and emerges from the patient in an easily accessible location such as beneath the head of the clavicle as in a Port-A-Cath. The catheter is coupled to an analyzer unit, thus forming a drug delivery system.

**[024]** The analyzer unit is a housing means for several key components of the apparatus. Cerebrospinal and/or tumor fluid that has returned from the patient passes through a lab-on-a-chip which measures and monitors the vascular endothelial growth factor (VEGF) levels for indications of progress or regression of the patient's tumor burden. The user or physician operating the apparatus can then adjust or change the drug regimen the patient is receiving based on these measurements. Also coupled to the unit are four piezoelectric pumps that send up to four different medicating agents through the catheter. A Blue Tooth<sup>®</sup> chip also allows the unit to be controlled by a physician from a remote location. Flash memory chips and an artificial intelligence processor complete the circuitry needed in order to provide the patient with an effective, easy to use apparatus that delivers medicating agents at a set and controlled rate. Finally, the analyzer unit or chemotherapy pumping device (CPD) includes a long lasting lithium ion battery that powers the unit itself.

**[025]** It is therefore an object of the invention to provide a patient with constant medication without re-implanting a catheter every time a patient needs to be treated.

**[026]** It is another object of the invention to provide a metronomic continuous delivery of a medicating agent.

**[027]** It is a further object of the invention to provide users and physicians in charge of a patient's treatment instant monitoring and feedback of various tumor parameters in order for the patient's treatment to be changed or adjusted accordingly.

**[028]** It is a further object of the invention to provide patients with tumors caused by leptomeningeal carcinomatosis an effective way of treating their affliction while minimizing the side effects of chemotherapy.

**[029]** Another object of the invention is to enhance the mechanism of vectorial change of tumor escape mechanism by introducing a sufficient tumor antigen to stimulate the immune system of the patient.

**[030]** Another object of the invention is to assist in irrigating the solid tumor by increasing cell adhesion molecules which are used for the adherence of cytotoxic cells to target cells before lysis can ensue. The malignant cells cannot bind to cytotoxic cells. The use of the apparatus will improve and enhance such a process.

**[031]** Yet another object of the invention is to administrate biological response modifiers (BRMs) with an improved dose, local delivery and scheduling on a case-specific basis using the programmable microcontroller and its associated valve mechanism.

**[032]** Another object of the invention is to allow the clinician the ability to prescribe an optimal biological dose (OBD) of medicating agent as opposed to maximum tolerated dose (MTD) of medicating agent by the use of an apparatus control mode defined by its programmability and its logic, which is embedded in microcontroller look-up-tables.

**[033]** Another object of the invention is to incorporate the pharmacokinetic and pharmacodynamic parameters associated with chemotherapeutic agents so as to achieve the desired results without the toxic side effects known to those familiar with the art.

**[034]** Another object of the invention is to modulate and modify the output of the medicating agent during treatment by changing the procedure in real time through the use of the command structure of the microcontroller look-up-tables with the use of a communication link built into the apparatus.

**[035]** Another object of the invention is to regulate the rate of dispensation of the medicating agent by modifying the duty cycle of the valve located in the apparatus.

**[036]** Another object of the invention is to regulate the intake of the tumor BRMs due to their pleiotropic nature, and allow for processes and mechanisms to develop by reducing or enhancing the various agents in the medicating apparatus (MBP), hence providing a treatment specific to the patient (e.g. tumor, size, lysis, etc).

**[037]** Another object of the invention is to provide the clinician a way to allow the expression of BRMs cascade effects (due to the communication of cytokines as messengers with their synergistic, additive or antagonistic interactions that affect the target tumor cells).

**[038]** Another object of the invention is to provide scheduling of medicating agents such as cytotoxic chemotherapy, BRMs, and others as based on their toxicity, and to allow for measures such as bioavailability, solubility, concentration, and circulation based on locality, both of which are the improved approach to the elimination of leptomeningeal carcinomatosis.

**[039]** Another object of the invention is to address the individual differences of various tumors based on the disease stage, immune factors, body weight, age and chronobiology through the ability of the apparatus to locally administer the agents, dosing, and scheduling.

**[040]** Another object of the invention is to provide an effective mode of administering BRMs with chemotherapy as a combination therapy by making available a local administration of different IFNs with IL-2 or IL-2 in combination with monoclonal antibodies and tumor necrosis factors (TFNs), and scheduling by the use of the invention under metronomic regimen.

**[041]** Another object of the invention is to enable drug manufacturers to evaluate the effectiveness of its drug during animal and clinical studies by providing the details and feedback on the use, dose, cycle, circadian time effects and the entire pharmacokinetic and pharmacodynamic behavior of the medicating agents not as verbal reports of symptomatology chronicles by the patient, but as a biological measure of tumor responses to the agents.

**[042]** Another object of the invention is to provide a method and apparatus for local administration of BRMs, cytotoxic chemotherapeutic agents, and others, to enhance mechanisms that support overlapping effects in reducing tumor burden and elimination of tumors. To induce an improved response by the use of biomodulators (augmenting the patient's anti-tumor response via production of cytokines), decreasing suppressor mechanisms, increasing the patient's immunological response, limiting the toxicity of such agents (by the locality), maximizing the dose, increasing susceptibility of

cells membrane characteristics for improved chemotherapy results at the site, and decreasing the tumor's ability to metastasize.

**[043]** The above characteristics are measurable elements since dosing and scheduling improves the effectiveness of chemotherapy on malignant cells and reduces the exposure of such toxins to normal tissues. One embodiment provides improved immunomodulation with relatively little immuno-suppression. Another object of the invention is to provide for defining an improved dose and schedule of biological agents to maximize the anti-tumor effects of each agent while not increasing toxicity to the patient. Treatment modality by the use of combination therapy and local administration of such agents on a specific schedule is one of the benefits of the invention.

**[044]** It is yet another object of the invention to provide preoperative simulation of the infusion of medicating agents into the spinal fluid to maximize infusion efficiency and minimize local toxicity by means of a diffusion model. The use of a drug diffusion model (DDM) inside the cranial vault permits a systematic design of targeted drug delivery into the ventricles and spinal subarachnoid space (SAS). Based on the computational fluid dynamics (CFD) approach, the model permits accurate prediction of drug diffusion in the cranial vault of the human brain based on the established transport and chemical kinetics models that describe the CSF motion in the brain. The model can be simulated in a computer-aided brain analysis before the actual placement procedure, thus reducing the need for trial-and-error animal experimentation or intuitive dosing in human trials.

**[045]** Finally, it is yet another object of the invention to provide operating physicians a method of treating leptomeningeal carcinomatosis without having to worry

about the medicating agent being diluted or hindered by the blood brain barrier (i.e. direct antibody injection into the tumor).

**[046]** While the apparatus and method has or will be described for the sake of grammatical fluidity with functional explanations, it is to be expressly understood that the claims, unless expressly formulated under 35 USC 112, are not to be construed as necessarily limited in any way by the construction of "means" or "steps" limitations, but are to be accorded the full scope of the meaning and equivalents of the definition provided by the claims under the judicial doctrine of equivalents, and in the case where the claims are expressly formulated under 35 USC 112 are to be accorded full statutory equivalents under 35 USC 112. The invention can be better visualized by turning now to the following drawings wherein like elements are referenced by like numerals.

#### **[047] Brief Description of the Drawings**

**[048]** Fig. 1a is a diagrammatic cross sectional view of a patient's body after the implantable pump unit has been successfully implanted the patient's lateral ventricle and the CPD has been implanted beneath the skin in the chest cavity.

**[049]** Fig. 1b is a block diagram of the architecture of the external control unit which communicates with the implanted apparatus.

**[050]** Fig. 1c is a diagram which illustrates the implantable pouch and its associated communications controller.

**[051]** Fig. 2 is an isometric view of the CPD.

**[052]** Fig. 3a is a front view of the CPD.

**[053]** Fig. 3b is a left side view of the CPD.

- [054] Fig. 3c is a right side view of the CPD.
- [055] Fig. 3d is a bottom view of the CPD.
- [056] Fig. 4a is a right side view of the CPD highlighting the delivery connector.
- [057] Fig. 4b is a magnified view of the delivery connector of Fig. 4a.
- [058] Fig. 4c is a bottom view of the CPD with an ampoule bay highlighted.
- [059] Fig. 4d is a magnified view of an ampoule bay of Fig. 4c.
- [060] Fig. 5 is a partially exploded view of the CPD.
- [061] Fig. 6 is a fully exploded view of the CPD.
- [062] Fig. 7a is a perspective view of the top of the induction charger assembly and pump electronics assembly coupled together.
- [063] Fig. 7b is a perspective view of the bottom of the induction charger assembly and pump electronics assembly coupled together.
- [064] Fig. 8a is a perspective view of the top of the pump electronics assembly.
- [065] Fig. 8b is a perspective view of the bottom of the pump electronics assembly.
- [066] Fig. 9a is a perspective view of the top of the induction charger assembly.
- [067] Fig. 9b is a perspective view of the bottom of the induction charger assembly.
- [068] Fig. 10a is an isometric view of the implantable leptomenigeal pump.
- [069] Fig. 10b is a diagram which depicts the "electrostatic muscle" defining the "supply mode" of the implantable spinal pump.
- [070] Fig. 10c is a diagram which depicts the "electrostatic muscle" defining the "pump mode" of the implantable spinal pump.

- [071] Fig. 11a is an isometric view of the implantable spinal pump with the pump-to-seal interconnect disconnected.
- [072] Fig. 11b is a magnified view of the pump head assembly.
- [073] Fig. 12 is a cross sectional view of the implantable spinal pump.
- [074] Fig. 13a is a partially cutaway cross sectional view of the implantable spinal pump with a plurality of injector spines highlighted.
- [075] Fig. 13b is a magnified view of the injector spines in the circled region 13a of Fig. 13a.
- [076] Fig. 13c is a magnified cross sectional view of the inner and outer membranes of the implantable cranium pump.
- [077] Fig. 14a is a side and cross sectional view of a hollow injector needle.
- [078] Fig. 14b is a side and cross sectional view of a spiral injector needle.
- [079] Fig. 15a is a front view of the pump actuator assembly.
- [080] Fig. 15b is a cross sectional view of the pump actuator assembly.
- [081] Fig. 16a is an exploded bottom view of the pump actuator assembly.
- [082] Fig. 16b is an exploded top view of the pump actuator assembly.
- [083] Fig. 17 is a functional block diagram of the pump actuator assembly.
- [084] The invention and its various embodiments can now be better understood by turning to the following detailed description of the preferred embodiments which are presented as illustrated examples of the invention defined in the claims. It is expressly understood that the invention as defined by the claims may be broader than the illustrated embodiments described below.

[085] **Definitions**



**[086]** Unless defined otherwise, all technical and scientific terms used herein have the same meanings as commonly understood by one of ordinary skill in the art to which this invention belongs. Although any methods and materials similar or equivalent to those described herein can be used in the practice or testing of the present invention, the methods, devices, and materials are now described. All publications mentioned herein are incorporated herein by reference for the purpose of describing and disclosing the materials and methodologies which are reported in the publications which might be used in connection with the invention. Nothing herein is to be construed as an admission that the invention is not entitled to antedate such disclosure by virtue of prior invention.

**[087]** The following mathematical symbols used here in refer to its definitions as follow:  $Q$  is infusate flow rate;  $\rho_f$  is drug fluid density;  $\vec{v}_f$  is drug fluid velocity in the catheter;  $\mu_f$  is drug fluid viscosity;  $D_b$  is bulk diffusivity of drug molecules;  $\rho_c$  is CSF density;  $\vec{v}_c$  is CSF velocity in the ventricular and subarachnoid systems;  $\mu_c$  is CSF viscosity;  $D_h$  is diffusivity of drug molecules in CSF;  $\varepsilon$  is tissue porosity;  $P$  is infusion fluid pressure;  $\vec{\nabla} P$  is pressure gradient;  $D_e$  is effective diffusion tensor;  $C_f$  is Concentration of drug;  $\vec{v}_t$  is fluid velocity in the porous tissue;  $D_e$  is mean effective diffusivity;  $k$  is permeability of the brain tissue;  $\mathfrak{R}$  is Hydraulic conductivity tensor, which is a function of fluid viscosity  $\mu$  and effective tissue permeability tensor  $\kappa$ ;  $\vec{v}_t \cdot \vec{\nabla} C_i$  is convection term;  $D_e \vec{\nabla} C_i$  is diffusion flux;  $C_i(\vec{x}, t)$  is tissue averaged species

concentration;  $R(C_t, \vec{x})$  is drug decomposition due to metabolic reaction;  $S(C_t, \vec{x})$  is sink terms due to bio-elimination.

#### [088] Detailed Description of the Preferred Embodiments

[089] The apparatus is additionally described and disclosed within U.S. Patent Application Serial Number 12/143,720 filed June 20, 2008, which is herein incorporated by reference in its entirety.

[090] The implantable pump unit 100 of the illustrated embodiment comprises an inner membrane 107 and an outer membrane 106 as seen in Fig. 13c. The space enclosed by inner membrane 107 is a medication reservoir 129 used for storing a medicating agent or a mixture of medicating agents as shown in Fig. 12.

[091] The size and volume of the medication reservoir 129 and thus the spinal pump 100 itself may be varied from patient to patient. A physician will make a determination of how much medication a particular patient will need and then the size of the medication reservoir 129 will be made accordingly. For example, a patient that needs large doses of medication will receive a spinal pump 100 with a larger medication reservoir 129 than a patient who only requires a small dose.

[092] Returning to Fig. 13c, the outer membrane 106 further comprises a plurality of micro pores 112 distributed throughout its entire surface. When the pump 100 is in the intake stroke, spinal fluid is drawn into the pump 100 through the micro pores 112 due to the pressure differential that exists between the inside of pump 100 and the surrounding area outside of the pump 100. The amount of spinal fluid that is drawn through the micro pores 112 is kept separated from the medication reservoir 129

by the inner membrane 107 and the lower portions of the injection spines 108. The volume of spinal fluid that is then contained between the inner membrane 107 and outer membrane 106 then forms a sampling cavity 111. The components of spinal pump 100 is preferably composed of silicone, as this is the material currently used for ventriculoperitoneal shunts. However additional materials such as biodegradable materials or other composites may be used without departing from the original spirit and scope of the invention.

**[093]** The implantable pump unit 100 further comprises a pump head 103 disposed on the top of pump 100 and a pump solenoid 104 disposed at the bottom of the pump 100. The detailed parts of the pump head 103 and pump solenoid 104 assemblies are shown in Figs. 15a-16b. In Fig. 15a, the pump solenoid 104 is comprised of a coil 119 which can generate magnetic fields either reinforcing or opposing the magnetic field of a permanent magnet 118. The permanent magnet 118 is made of NbFe<sub>35</sub> ceramic material however other materials may be used without departing from the original scope and spirit of the invention. The coil 119 may then be pulled or pushed away from the permanent magnet 118 depending on the current polarity of the coil 119. The coil 119 is coupled to a bobbin 120 and is constructed from a plurality of small (40AWG) windings. The bobbin 120 is composed of several layers of bobbin washers 121. Because bobbin 120 is attached to the flexile skin-like material of the inner membrane 107 of the pump 100, the coil 119 movement translates into an increase or decrease of pressure on the medication reservoir 129.

**[094]** Controlling the amount of electrical current that passes through the coil 119 produces variable and regulated medication pressure which in turn adjusts the

amount of medicating agent passing through a plurality of injector spines 108 described above. Conversely, the controlled movement of the coil 119 acts as a pumping function serving to provide suction to the outer membrane 106 of the pump and thus draw in surrounding spinal fluid from the patient.

**[095]** The apparatus uses a method similar to respiration to not only pump drugs into the spinal column containing cancer cells, but also to sample the immediate area by creating a negative pressure in the sampling cavity 111. As can be seen in Fig. 12, the pump solenoid 104 and pump head 103 use a magnet 118 and coil 119 as a solenoid to create attraction or repulsion between the pump head 103 and the bobbin 120. This motion is then translated to the pump 100. The outer membrane 106 is made of a more ridged durra silicon rubber than the inner membrane 107. When the pressure is reversed by the pump solenoid 104, because the inner membrane 107 is softer than the outer membrane 106, the gap between the membranes increases and the negative pressure sucks in the spinal fluids through the aspirator micro-pores 112 around the spines 108 on the outer membrane 106. Turning back to Figs. 15a and 15b, this sample fluid then gets removed between a sampling washer 115 through sampling collection ducts 128 in a delivery/sampling head 114 and out through a connector plate 113.

**[096]** The connector plate 113 has both a drug inlet 122 and a sampling tube 123 connection. The connector plate 113 also comprises all the electrical connections for the coil 119, the pressure sensor 131 (shown in Fig. 12) and the temperature sensors 132 (also shown in Fig. 12). The top of drug inlet 122 and the sampling tube 123 as well as various sensor and coil connections can be seen in Fig. 11b.

**[097]** Figs. 16a and 16b best show that the electrical connections are transferred through a series of sensor and coil pins 126 through the delivery/sampling head 114 to a plurality of sensor and coil connections 125 in the inner medication reservoir 129. Connections to the coil 119 are made with insulated flexible wire 130 (shown in Fig. 12).

**[098]** Turning back to Figs. 16a and 16b, the inner and outer membranes 107, 106 are attached and compressed by washers 121 to the bobbin 120. The bobbin 120 freely travels over the permanent NdFeB magnet 118. The magnet 118 is permanently coupled to the delivery/sampling head 114. The inner and outer membranes 107, 106 are also coupled directly to the delivery/sampling head 114. The sampling washer 115 and the bobbin 120 also provide the necessary gap of 0.020 inch for the medication reservoir 129. A compression nut 117 compresses an inner membrane washer 116 to clamp the inner membrane 107 against the delivery/sampling head 114. As seen in Fig. 15b, the delivery/sampling head 114 also comprises a drug dispersion tube 124 which releases the medicating agent or mixture of medicating agents to be administered to the patient into the medication reservoir 129.

**[099]** Turning back to Fig. 10a, at the head of the spinal pump 100, the pump head assembly 103 is coupled to a seal connector 102 via a series of fluid lines and electronic connections enclosed in a pump-to-seal interconnect 101. The seal connector 102 is essentially a valve that controls the amount of fluid that is permitted to enter or leave the pump 100. When more medicating agent is needed, the seal connector 102 opens and allows the medicating agent to travel through the pump-to-seal interconnect 101 and enter the medication reservoir 129 below. When the correct

amount of medicating agent has been applied, the seal connector 102 closes and all incoming fluid flow stops. Additionally, the seal connector 102 houses a suction nozzle (not shown) that applies suction to the sampling cavity 111 and draws up recently acquired spinal fluid up and out of the pump 100 and through the seal connector 102.

**[0100]** Figs. 10b and 10c further depict the pump mode 145 and supply mode 144 as it is employed by the spinal pump 100. Figure 10b and 10c depict the electrostatic muscle 64 in its closed state 134 which is also the supply mode 144, where the medicating agent or BRM are pumped out and transported from the spinal pump 100 to the desired tumor site or biological tissue of interest.

**[0101]** In Figure 10b, the inlet nozzle is shown as 136, while an increasing chamber volume 141 is taking place. The increase in chamber volume causes flow 138 from the inlet 136 to enter the chamber 142 and at the same time, there is a small amount of fluid which flows from the outlet 137 into the chamber 142 as well. However, because of the venturi action of the inlet 136 and the outlet 137, the total net flow is from the spinal pump 100 into the chamber 142. In this case, the inlet 136 exhibits a diffuser action 143 and the outlet 137 exhibits a nozzle action 140.

**[0102]** Fig. 10c exhibits the electrostatic muscle 64 in its open state 135, which is also the pump mode 145. In this case there is a decrease in chamber volume 151, which causes a net flow to take place from the chamber 150 to the tumor site 41 through the outlet 148. Although there is a small amount of flow 147, from the chamber 150 to the inlet, the net flow is substantial and is from the chamber 150 to the tumor site 41. In this mode, the inlet 147 exhibits a nozzle action, 152 and the outlet exhibits a diffuser action 149.

**[0103]** Turning to Fig. 1a, a delivery hose 200 is coupled to the seal connector 102 and a chemotherapy pump device (CPD) 1 portion of the apparatus. The delivery hose 200 thus serves as a conduit between the pumping and analyzing portions of the current invention and houses a refill line, a return sample fluid line, and several electronics connections for various sensors and the coil 119.

**[0104]** The seal connector 102 is coupled to pump 100 and is firmly embedded within the patient with the top portion of the shunt protruding from the patient. The delivery hose 200 is coupled to the seal connector 102 and leads away from the pump 100 and up the back of the neck of the patient underneath the skin. The purpose for maintaining the catheter 200 beneath the skin is to give the patient a sense of normalcy and confidence while they are undergoing treatment.

**[0105]** Fig. 1b shows an external analyzer unit 300 which communicates with the CPD 1. The CPD 1 communicates with the external analyzer 300 by the use of RF transmitter 304 and its associated antenna 302 and RF receiver 303 with its associated antenna 301. After implantation of the CPD 1 subcutaneously inside the patient 39, the system allows for programmability of the device in order to dispense the medicating agent in proper intervals over time and in the prescribed doses. Once the CPD 1 and spinal pump 100 is implanted and is in operation, the clinician may decide to change the parameters of the operation such as the amount of medication dispensed onto the tumor site or the time intervals associated with the dispense process. The clinician communicates with the internal electronics of CPD 1 using an external analyzer unit 300 shown in Fig. 1b, which may be in the form of a desktop computer or any other similar appropriate device. The external analyzer unit 300 is able to communicate with the

microcontroller in CPD 1 through its own microcontroller 305 via RF transmitter 304, its antenna 302, and the RF receiver 303 and its antenna 301, or via the serial communication port 307, located in the external analyzer unit 300. The new sets of commands are then transferred to the spinal pump 100. These new command data are then stored in the memory of the microcontroller of CPD 1, which is now programmed anew to perform the procedure as coded in the new instruction set.

[0106] In one embodiment, the external analyzer unit 300 is used to implement computer software that provides preoperative simulation of the infusion of medicating agents to maximize infusion efficiency and minimize local toxicity by means of a diffusion model. The drug diffusion model (DDM) takes into account the brain geometry, the way CSF is produced in the choroid plexus from the blood and also from the brain tissue from which it is believed to seep through the porous extracellular space towards the ventricles, as well as the CSF flow through the ventricles and SAS. This model does not consider other intracranial dynamics conditions such as the pulsating CSF motion due to expansion of the parenchyma and choroid plexus in the systole during a cardiac cycle.

[0107] In the first step, the patient-specific MRI is used to extract the anatomically accurate geometry of CSF spaces inside the brain, as well as the CSF flow velocities in select regions of the brain. In the second step, the brain region is partitioned into small discrete volume grids. In the third step, a set of equations and boundary conditions describe flow physics and mass transfer between the finite volumes in the brain region. In the final step, the equations are solved numerically over the finite volume and the boundaries between the adjacent volumes.



**[0108]** The patient specific brain imaging data not only permits reconstruction of physiologically accurate substructures and boundaries between regions in the brain, but also enables measuring CSF flow fields and velocities *in vivo*. Brain properties such as porosity, diffusivity, and permeability, as well as CSF parameters such as viscosity and density can be estimated from the brain location and reference literature. These parameters combined with basic fluid physics enable quantification of the multidirectional CSF flow fields that are consistent with the clinical observation in major CSF pathway sections of the brain.

**[0109]** The brain including SAS is partitioned into small triangular and quadrilateral elements by applying Delaunay triangulation. The brain tissue is assumed to be a homogeneous isotropic porous medium for simplicity. Each small finite volume is linked to its neighbors so as to form a logically connected computational mesh, which can be generated by commercial grid generator tools such as Gambit. The grid sizes need to be large enough to minimize the number of volume elements for calculations yet small enough to be able to spatially resolve the anatomical properties of the tumor area. A typical simulation consists of approximately 100,000 volume elements distributed throughout the brain. The flow and mass transfer equations are enforced over the computational domain consisting of these meshes.

**[0110]** The drug delivery to the ventricles is simply modeled as inserting aqueous solution consisting of drug solutes via an infusion catheter into a large pool of CSF, which naturally flows and interacts with surrounding porous brain tissues. Both CSF and drug solution are assumed to be incompressible Newtonian fluids whose motion inside the brain can be described by the mass and momentum conservation equation.

Additionally, the drug diffusion is described by the species transport and chemical kinetics equations. The drug diffusion model consists of four parts: the flow inside the catheter, the flow in the ventricular and subarachnoid systems, the flow in porous brain tissues, and the boundary conditions for intracranial dynamics between the CSF and various brain tissues.

[0111] For the flow inside the catheter, the model divides the space inside the lumen of the catheter into small finite elements. The fluid flow between the finite elements is modeled with the continuity and Navier-Stokes equations as shown in Equations 1 and 2, respectively. The continuity equation (Eq 1) describes that the drug fluid is incompressible.

$$[0112] \quad \vec{\nabla} \cdot (\rho_f \vec{v}_f) = 0 \quad (1)$$

[0113] The Navier-Stokes equation (Eq 2) describes that the momentum of the fluid flow is conserved. It states that any change in fluid velocity in the catheter (the left-hand side of the equation) is due to the pressure gradient (caused by the pumps) and resistance of the flow due to fluid viscosity.

$$[0114] \quad \rho_f \left( \frac{\partial \vec{v}_f}{\partial t} + \vec{v}_f \cdot \vec{\nabla} \vec{v}_f \right) = -\vec{\nabla} p + \mu_f \vec{\nabla}^2 \vec{v}_f \quad (2)$$

[0115] The movement of the drug molecules inside the catheter due to the flow can be modeled with the species transport equation as shown in Equation 3. It states that the change in concentration of the molecules due to diffusion and convection (the left-hand side of the equation) depends on the divergent of the product of the diffusivity and concentration gradient of the molecules in the fluid.

$$[0116] \quad \frac{\partial C_f}{\partial t} + \vec{v}_f \cdot \vec{\nabla} C_f = \vec{\nabla} \cdot \left( D_b \vec{\nabla} C_f \right) \quad (3)$$

[0117] The fluid flow inside the ventricles is dictated by the natural CSF flow in the ventricular and subarachnoid systems. At the tip of the catheter, the CSF velocity is the same as the fluid velocity coming out of the catheter:  $\vec{v}_c = \vec{v}_f$ . Because the CSF is also assumed to be an incompressible Newtonian fluid, the CSF motion can be described by the continuity and the Navier-Stokes equations as shown in Equations 4 and 5, respectively. The continuity equation (Eq 1) describes the conservation of mass of CSF.

$$[0118] \quad \vec{\nabla} \cdot \left( \rho_c \vec{v}_c \right) = 0 \quad (4)$$

[0119] The conservation momentum of the fluid flow is described by Navier-Stokes equation (Eq 5). It states that any change in fluid velocity in the ventricular and subarachnoid systems (the left-hand side of the equation) is due to the pressure gradient (between ventricles and SASs) and resistance of the flow due to CSF viscosity.

$$[0120] \quad \rho_c \left( \frac{\partial \vec{v}_c}{\partial t} + \vec{v}_c \cdot \vec{\nabla} \vec{v}_c \right) = -\vec{\nabla} p + \mu_c \vec{\nabla}^2 \vec{v}_c \quad (5)$$

[0121] Like in Equation 3, the movement of the drug molecules inside the ventricles and SASs due to the flow can be modeled with the species transport equation as shown in Equation 6. It states that the change in concentration of the molecules due to diffusion and convection (the left-hand side of the equation) depends on the divergent of the product of the diffusivity and concentration gradient of the molecules in the CSF.

$$[0122] \quad \frac{\partial C_f}{\partial t} + \vec{v}_c \cdot \vec{\nabla} C_f = \vec{\nabla} \cdot \left( D_c \vec{\nabla} C_f \right) \quad (6)$$

[0123] The fluid flow inside the brain tissues is modeled as the fluid flow in a porous medium. The brain is partitioned into small finite elements and the flow between these elements is modeled with the continuity equation and Darcy's Law as shown in Equations 7 and 8, respectively. The continuity equation (Eq 8) describes that the loss of fluid in the flow is due to the absorption into the porous medium. The fluid velocity in tissue is related to average CSF velocity,  $\vec{v}_t = \varepsilon \vec{v}_c$  through the porosity of brain tissue. The amount of fluid loss captured in the sink term is a function of the difference between the interstitial fluid pressure and the venous pressure:  $S_B = f(p - p_v)$ .

[0124] 
$$\vec{\nabla} \cdot (\rho_c \vec{v}_t) = S_B \tag{7}$$

[0125] The fluid dynamics in the porous brain tissue is embodied in the Darcy's Law (Eq 8), which states that the momentum of the fluid flow is conserved. It states that any change in fluid velocity in the brain (the left-hand side of the equation) is due to the pressure gradient (caused by the pressure drop in the porous medium) and resistance of the medium to the flow.

[0126] 
$$\frac{\rho_c}{\varepsilon} \left( \frac{\partial \vec{v}_t}{\partial t} + \varepsilon^{-1} (\vec{v}_t \cdot \vec{\nabla}) \vec{v}_t \right) = -\vec{\nabla} p - \mathfrak{R}^{-1} \vec{v}_t \tag{8}$$

[0127] where the resistance of the porous brain tissue can be defined as

$$\mathfrak{R}^{-1} \vec{v}_t = \frac{\mu_c}{k} \vec{v}_t + \frac{\beta \rho}{2} v_t^2 - \mu_c \vec{\nabla}^2 \vec{v}_t$$

[0128] The movement of the drug molecules inside the brain tissue due to the flow described in Eq 8 can be modeled with the species transport equation as shown in Equation 9. It states that the change in concentration of the molecules due to diffusion

and convection (the left-hand side of the equation) depends on the divergent of the product of the diffusivity tensor of the brain medium and concentration gradient of the molecules in the fluid. The accuracy of the model can be improved by incorporating the loss of drug molecules due to decomposition and bio-elimination.

$$[0129] \quad \varepsilon \frac{\partial C_i}{\partial t} + \vec{v}_i \cdot \vec{\nabla} C_i = \vec{\nabla} \cdot \left( D_e \vec{\nabla} C_i \right) + R \left( C_i, \vec{x} \right) + S \left( C_i, \vec{x} \right) \quad (9)$$

[0130] The completeness of the diffusion model is captured in the boundary condition assumptions listed below. At the catheter inlet, the infusion flow rate or pressure and concentration of drug are assumed to be constant. At the interior wall inside the lumen of the catheter, the flow is assumed no slip,  $\frac{\partial p}{\partial n} = 0$ , and the drug doesn't penetrate (zero flux) into the catheter wall,  $\vec{n} \cdot \vec{\nabla} C_f = 0$  and  $\vec{v}_f = 0$ . At the outer surface of the catheter, the same boundary conditions are assumed as in the inside. At the catheter tip, the continuity of flow is assumed:  $\vec{v}_f \Big|_{lumen} = \vec{v}_{cout} = \vec{v}_i$ , and,

$p_{lumen} = p_{cout}$ , and  $C_f \Big|_{lumen} = C_i$ . At the ventricles or SASs, the fluid pressure is the same as the pressure of the Cerebrospinal fluid (CSF). Bio-elimination "sink term" is assumed as a function of the difference between interstitial pressure and venous pressure:  $S_b = f(p - p_v)$ .

[0131] The nine partial differential equations (Eq 1-9) are applied to the discrete volumes in the model to produce a set of non-linear algebraic equations for the entire brain model. These equations are solved with proper boundary condition using the

iterative Newton-Krylov method and simulated using commercial fluid dynamics software such as Fluent.

**[0132]** The microcontroller located in CPD 1 and implanted inside the patient's body 39 communicates with the external analyzer unit 300 via RF transmitter 304 and RF receiver 303 thereby sending its collected data to the external analyzer unit 300. This feature enables the clinician to collect data and to determine the state of the patient throughout the period of treatment. These data are stored inside the external analyzer unit 300 providing chart history of the treatment status of the parameters associated with the tumor site. The CPD 1 transmits data for collection and storage. The external analyzer unit 300 is controlled by the user via the settings in control 308 and it also displays the amount of medicating agent dispensed over time by the spinal pump 100 on its display 309. Data collected in this manner can be used to correlate behavior pattern of a particular patient and his or her chart history. One can write a data collection and analysis program which can be displayed by the external analyzer unit 300. Once the data are collected from the CPD 1, the external analyzer unit 300 or the host PC can then plot the data on a time scale and analyze the data further. It is significantly better to correlate between the input and the output or between cause and effect to mirror the action of the pump 100 and its host tumor site. Such data in the form of historical plot of cause and effect benefit the patient 39 and aide in future research. The entire unit as shown in Fig. 1b is run by power obtained from its power source 306.

**[0133]** Fig. 1c is an illustration of a patient 39 with tumor caused by leptomeningeal carcinomatosis with the implanted pump 100. The external analyzer unit 300 with its associated serial port 307 and receiver and transmitter antennae 301

and 302 respectively is shown in its bidirectional communication model with the implanted CPD 1 via the RF path 310.

**[0134]** Turning to Fig. 4a, the CPD 1 comprises a delivery connector 7 where the delivery hose 200 couples with the CPD 1. The delivery connector 7 contains a drug outlet 4, a sample return 5, and a plurality of sensor connections 6 for controlling the pump unit 100 and for analyzing the sample fluid that is obtained from the spine of the patient. The drug outlet 4 is the aperture in which a medicating agent or mixtures of medicating agents are sent from the CPD 1 through the delivery hose 200. Similarly, the sample return 5 is the aperture where spinal fluid that has been collected by pump 100 is returned by the delivery hose 200 and enters the CPD 1 for analysis. The process by which the external CPD 1 sends a medicating agent or mix of medicating agents and receives sample fluid obtained from the patient through the delivery hose 200 is explained in further detail below.

**[0135]** Up to four drug ampoules 2 (Fig. 2) can be deposited on the bottom portion 10 of the external CPD 1 in four separate ampoule bays 8 as depicted in Fig. 3d. It is to be expressly understood that fewer or additional ampoule bays may be present without departing from the original spirit and scope of the invention. To introduce medicating agent into the CPD 1, a drug ampoule 2 is inserted into the ampoule bay 8. Drug needles 18 extending from the interior of the CPD 1 shown in Fig. 7a penetrate the ampoules 2 and carry the medicating agent. The CPD 1 then draws in the medicating agent in a series of steps that are described below.

**[0136]** Turning to Fig. 6, the interior of the CPD 1 is comprised of two assemblies; a pump electronics assembly 12 and an induction charger assembly 11. The pump

electronics assembly 12 and the induction charger assembly 11 are both housed within the external CPD 1 and are joined by an electronics interconnect cable 13 as best seen in Figs. 7a and 7b.

**[0137]** The pump electronics assembly 12 is shown in greater detail in Figs. 8a and 8b. As seen in Fig. 8b, the pump electronics assembly 12 contains a drug delivery CPU 27 that stores its program and data into two FLASH memories 28. Pre-stored information such as look-up tables and the like are stored on the FLASH memories 28. The drug delivery CPU 27 runs a pre-installed intelligent chemo delivery software program and controls an ampoule pump integrated circuit 20, a return pump integrated circuit 19, and a delivery valve drift integrated circuit 22 as seen in Fig. 8a. The drug delivery CPU 27 also communicates with a lab-on-a-chip 21 and receives important treatment data such as sample temperature data through the sensor inputs 6 in the delivery connector 7 seen best in Fig. 6.

**[0138]** The drug delivery CPU 27 is pre-programmed and is capable of transmitting data through a Bluetooth® transceiver 29. The Bluetooth transceiver 29 is connected to a Bluetooth® antenna 30. A user or qualified physician who wishes to change the patient's drug regimen from a remote location first sends the data to the patient. The sent information is then picked up by the Bluetooth® transceiver 29 and antenna 30 and is then stored on the FLASH memory chips 28. When the drug delivery CPU 27 retrieves information from the FLASH memory chips 28 it adjusts the drug regimen (dose, scheduling, etc.) according to the user's data instructions.

**[0139]** The external CPD 1 is capable of delivering up to four different drugs simultaneously with high accuracy in the following manner: The pump electronics



assembly 12 of Fig. 8a comprises up to four piezoelectric pumps 17 driven by a corresponding ampoule pump integrated circuit 20 that together pump the medicating agent out of the ampoule 2. The use and manufacture of piezo pumps are well known to those in the art. Fewer or additional piezo pumps 17 than what is depicted in Fig. 8a may be used without departing from the original spirit and scope of the invention. The pump needles 18 are sufficiently long enough so that when a drug ampoule 2 is attached to the piezo pump 17 as depicted in Fig. 2, the medicating agent at the bottom of the ampoule may be accessed. Pump needles 18 coupled to the piezoelectric pumps 17 penetrate the ampoules 2 and the piezoelectric pump 17 pumps the medicating agent through a drug manifold tube 24 and into a delivery valve 15 and out through the drug delivery connector 7. The delivery valve 15 is regulated by a delivery valve driver integrated circuit 22 which is controlled by the drug delivery CPU 27. The medicating agent, after being pumped through the delivery connector 7, then enters into the delivery hose connector 37 (Fig. 5) via the drug output 4 on the delivery connector 7 depicted in Fig. 4b. The medicating agent is then pumped through the delivery hose 200 and into the spinal pump unit 100 via the seal connector 102. In Fig. 5, the delivery hose 200 couples to the CPD 1 via a delivery hose connector 37.

**[0140]** The external CPD 1 is fully programmable and runs intelligent software to determine what and how much drug is required. The regulation loop of the intelligent drug delivery system uses a return sample of fluids from the "delivery area" to determine the necessary response. In Fig. 5, the return sample fluid obtained from the patient travels through the delivery hose 200, through the delivery hose connector 37, and then enters delivery connector 7 through the sample return 5 as shown in Fig. 4b. Turning to

Fig. 8a, after the sample fluid passes from the delivery connector 7, the sample fluid enters the delivery valve 15. The negative pressure necessary to pump the sample is created by the return piezoelectric pump 16 that is powered by a return pump driver integrated circuit 19. The fluid sample then travels from the delivery valve 15 into a return pump input tube 25 and into a lab-on-a-chip 21 that senses the chemical composition of the sample. The return piezoelectric pump 16 continues pumping the sample fluid through itself and back out into a return output pump tube 23. The sample fluid is then mixed together with the delivery drug in the delivery valve 15, to continue a closed loop cycle to be returned to the collection site.

**[0141]** The second main assembly, the induction charger assembly 11, is depicted in greater detail in Figs. 9a and 9b. The induction charger assembly 11 provides with a means for charging a lithium ion battery 14 (shown in Fig. 5). An induction coil 38 coupled to the induction charger electronics assembly 11 receives a high frequency (50Khz) induced magnetic field from a similar charging coil from an external battery charger device (not shown). The induction coil 38 is coupled to a rectifier 35 shown in Fig. 9b. The rectifier 35 converts the high frequency voltage to a DC voltage that is filtered by an inductor 34 and capacitors 33. A battery charger controller 32 regulates the charging of the battery 14. The charger connector 36 is both for powering the electronics as well as charging the lithium ion battery 14. The battery 14 is appropriately sized to provide sufficient power for days of service without the need of charging.

**[0142]** The lithium ion battery 14 preferably has an "L" shape as shown in Fig. 6 so as to leave sufficient space available for the pump needles 18 and drug ampoules 2

within the housing of the CPD 1 and is sized to provide sufficient power for days of service without the need of re-charging. However it is to be expressly understood that other varieties of batteries with various life spans and shapes may also be used without departing from the original scope and spirit of the invention. The lithium ion battery 14 is coupled directly to the housing of the CPD 1 and is removable so that when the stored energy has been depleted from the battery 14, it may be easily replaced.

**[0143]** Filling the ampoules 2 with medicating agent and having the medicating agent then delivered intratumor by the pump 100 and its injector spines 108, eliminates the blood barrier as a potential obstacle. As discussed above, most medicating agents would normally have a difficult time getting to the cancer cells directly without the pump 100 penetrating the blood barrier. Delivering the medicating agent directly into the tumor also allows for more concentrated doses which eliminates the side effects associated with the systemic intravenous delivery of medicating agents listed above, including hydrocephalus which can be catastrophic to the patient. Finally, the pump 100 eliminates the need for repeat puncture of the Ommaya reservoir or repeat lumbar punctures, thus improving patient safety from risk of infection or discomfort from repeat lumbar punctures.

**[0144]** In patients in whom a resection cannot be performed, an alternative embodiment of the current invention involving a multidelivery catheter 200 is employed. A method for delivering a medicating agent into the cerebrospinal fluid (CSF) in a patient comprises surgically implanting a multidelivery catheter 200 beneath the skin of the patient into a treatment site. The multidelivery catheter 200 is then coupled to an external analyzer unit 300. The external analyzer unit 300 is the same external

analyzer unit 300 described above with regard to the previous embodiment. The multidelivery catheter 200 is then operated within the CSF of the patient in order to infuse the medicating agent to the treatment site. The multidelivery catheter 200 is then used to suction in a sample of the CSF from the treatment site and transfer it to the external analyzer unit 300. In the same manner as described above with regard to the previous embodiment, the external analyzer unit 300 is then used to track and monitor the progress of the patient's treatment via the external analyzer unit 300. Additionally in the same manner as described above with the previous embodiment, the external analyzer unit 300 comprises the means for altering and changing the patient's treatment. Finally, a reservoir of medicating agent located within the external analyzer unit 300 may be refilled and replenished as needed.

**[0145]** Also as similarly described above, the external analyzer unit 300 comprises means for displaying the amount of medicating agent dispensed over time by the multidelivery catheter 200 within the treatment site.

**[0146]** In one particular embodiment, the suctioning in of the sample CSF from the treatment site comprises suctioning in the sample CSF in at least two proximal ports (not shown) defined in the proximal end of the multidelivery catheter 200. The means for tracking and monitoring the progress of the patient's treatment by the external analyzer unit 300 further comprises passing the sample CSF through a means for spinal fluid analysis in the external analyzer unit 300. The sample of CSF passes through a means of analysis on the external analyzer unit 300 that comprises means for measuring the effectiveness of the administration of the medicating agent.

**[0147]** In another embodiment, the method step of measuring the effectiveness of the medicating agent administration further comprises displaying the results obtained from the means of the analyzer unit on a display.

**[0148]** In an alternative embodiment, the external analyzer unit 300 further comprises means for providing a preoperative simulation of the infusion of the medicating agent to maximize efficiency and minimize toxicity by means of a diffusion model.

**[0149]** The external analyzer unit 300 further comprises entering command functions and data into the external analyzer unit 300 from a remote keypad (not shown) and displaying the commands on a display 309. The entering of command functions may comprise sending command functions and data to the external analyzer unit 300 by means of a Bluetooth® transceiver and antenna.

**[0150]** The refilling and replacing of the reservoir of medicating agent located in the analyzer unit also comprises refilling and replacing at least four drug ampoules coupled to the analyzer unit.

**[0151]** Figure 17 is a functional circuit diagram further illustrating the relationship between the elements of CPD 1 described above.

**[0152]** It is to be expressly understood that the disclosed device may also be used to treat cranial neuropathies associated with leptomeningeal carcinomatosis secondary to cancer seeding on the cranial nerves. Such neuropathies include but are not limited to facial paralysis, diplopia, and difficulty swallowing. Due to the current device's ability to administer more than one medicating agent at a time, treatment of these cranial neuropathies may be carried out separately or concurrently with the

treatment of the cancer cells contained within the spinal fluid of a patient as described above.

**[0153]** Many alterations and modifications may be made by those having ordinary skill in the art without departing from the spirit and scope of the invention. Therefore, it must be understood that the illustrated embodiment has been set forth only for the purposes of example and that it should not be taken as limiting the invention as defined by the following invention and its various embodiments.

**[0154]** For example, one skilled in the art may produce a device with fewer or additional drug ampoule bays or piezoelectric pumps without departing from the original scope and spirit of the invention.

**[0155]** Therefore, it must be understood that the illustrated embodiment has been set forth only for the purposes of example and that it should not be taken as limiting the invention as defined by the following claims. For example, notwithstanding the fact that the elements of a claim are set forth below in a certain combination, it must be expressly understood that the invention includes other combinations of fewer, more or different elements, which are disclosed in above even when not initially claimed in such combinations. A teaching that two elements are combined in a claimed combination is further to be understood as also allowing for a claimed combination in which the two elements are not combined with each other, but may be used alone or combined in other combinations. The excision of any disclosed element of the invention is explicitly contemplated as within the scope of the invention.

**[0156]** The words used in this specification to describe the invention and its various embodiments are to be understood not only in the sense of their commonly

defined meanings, but to include by special definition in this specification structure, material or acts beyond the scope of the commonly defined meanings. Thus if an element can be understood in the context of this specification as including more than one meaning, then its use in a claim must be understood as being generic to all possible meanings supported by the specification and by the word itself.

**[0157]** The definitions of the words or elements of the following claims are, therefore, defined in this specification to include not only the combination of elements which are literally set forth, but all equivalent structure, material or acts for performing substantially the same function in substantially the same way to obtain substantially the same result. In this sense it is therefore contemplated that an equivalent substitution of two or more elements may be made for any one of the elements in the claims below or that a single element may be substituted for two or more elements in a claim. Although elements may be described above as acting in certain combinations and even initially claimed as such, it is to be expressly understood that one or more elements from a claimed combination can in some cases be excised from the combination and that the claimed combination may be directed to a subcombination or variation of a subcombination.

**[0158]** Insubstantial changes from the claimed subject matter as viewed by a person with ordinary skill in the art, now known or later devised, are expressly contemplated as being equivalently within the scope of the claims. Therefore, obvious substitutions now or later known to one with ordinary skill in the art are defined to be within the scope of the defined elements.

**[0159]** The claims are thus to be understood to include what is specifically illustrated and described above, what is conceptionally equivalent, what can be obviously substituted and also what essentially incorporates the essential idea of the invention.



### Claims

1. A method for delivering medicating agent into the cerebrospinal fluid (CSF) in a patient comprising:
  - surgically implanting a catheter into the CSF of the patient at a defined treatment site;
  - coupling the distal end of the catheter to a magnetically operated spinal pump disposed at the treatment site;
  - coupling the proximal end of the catheter to an analyzer unit disposed outside of the treatment site;
  - operating the pump within the CSF of the patient in order to infuse medicating agent to the treatment site;
  - suctioning in a sample of the CSF from the treatment site and transferring the CSF sample to the analyzer unit;
  - tracking and monitoring the progress of the patient's treatment via the analyzer unit;
  - altering and changing the patient's treatment by controlling the analyzer unit; and
  - refilling and replacing a reservoir of medicating agent located in the analyzer unit.

2. The method of claim 1 where operating the magnetically operated spinal pump comprises contracting and expanding an inner membrane reservoir in the spinal pump by oscillation of a magnetic solenoid.
3. The method of claim 1 where suctioning in the sample of the CSF further comprises suctioning the sample CSF into an intra-membrane reservoir defined between an outer and inner membrane in the spinal pump by the oscillation of a magnetic solenoid.
4. The method of claim 1 where tracking and monitoring the progress of the patient's treatment further comprises passing the sample of spinal fluid through a means for spinal fluid analysis in the analyzer unit.
5. The method of claim 4 where passing the sample of spinal fluid through a means of analysis further comprises measuring the effectiveness of intratumoral medicating agent administration by means of the analyzer unit.
6. The method of claim 5 where measuring the effectiveness of intratumoral medicating agent administration further comprises displaying the results obtained from the means of the analyzer unit on a display.

7. The method of claim 1 further comprising providing a preoperative simulation of the infusion of the medicating agent to maximize efficiency and minimize toxicity by means of a diffusion model.
8. The method of claim 1 where altering and changing the patient's treatment by controlling the analyzer unit further comprises entering command functions and data into the analyzer unit from a remote keypad and displaying the commands on a display.
9. The method of claim 8 where altering and changing the patient's treatment by controlling the analyzer unit further comprises sending command functions and data to the analyzer unit by means of a Bluetooth® transceiver and antenna.
10. The method of claim 1 where refilling and replacing the reservoir of medicating agent located in the analyzer unit further comprises refilling and replacing at least four drug ampoules coupled to the analyzer unit.
11. A method for delivering a medicating agent into the cerebrospinal fluid (CSF) in a patient comprising:
- surgically implanting a multidelivery catheter beneath the skin of the patient into a treatment site;
  - coupling the multidelivery catheter to an analyzer unit;
  - operating the multidelivery catheter within the CSF of the patient in order to infuse the medicating agent to the treatment site;

suctioning in a sample of the CSF from the treatment site and transferring it to the analyzer unit;

tracking and monitoring the progress of the patient's treatment via the analyzer unit;

altering and changing the patient's treatment by controlling the analyzer unit; and

refilling and replacing a reservoir of medicating agent located in the analyzer unit.

12. The method of claim 11 where tracking and monitoring the progress of the patient's treatment via the analyzer unit further comprises displaying the amount of medicating agent dispensed over time by the multidelivery catheter within the treatment site.

13. The method of claim 11 where suctioning in the sample CSF from the treatment site comprises suctioning in the sample CSF in at least two proximal ports defined in the proximal end of the multidelivery catheter.

14. The method of claim 11 where tracking and monitoring the progress of the patient's treatment further comprises passing the sample CSF through a means for spinal fluid analysis in the analyzer unit.

15. The method of claim 14 where passing the sample of spinal fluid through a means of analysis further comprises measuring the effectiveness of the medicating agent administration by means of the analyzer unit.

16. The method of claim 15 where measuring the effectiveness of the medicating agent administration further comprises displaying the results obtained from the means of the analyzer unit on a display.

17. The method of claim 11 further comprising providing a preoperative simulation of the infusion of the medicating agent to maximize efficiency and minimize toxicity by means of a diffusion model.

18. The method of claim 11 where altering and changing the patient's treatment by controlling the analyzer unit further comprises entering command functions and data into the analyzer unit from a remote keypad and displaying the commands on a display.

19. The method of claim 18 where altering and changing the patient's treatment by controlling the analyzer unit further comprises sending command functions and data to the analyzer unit by means of a Bluetooth® transceiver and antenna.

20. The method of claim 11 where refilling and replacing the reservoir of medicating agent located in the analyzer unit further comprises refilling and replacing at least four drug ampoules coupled to the analyzer unit.

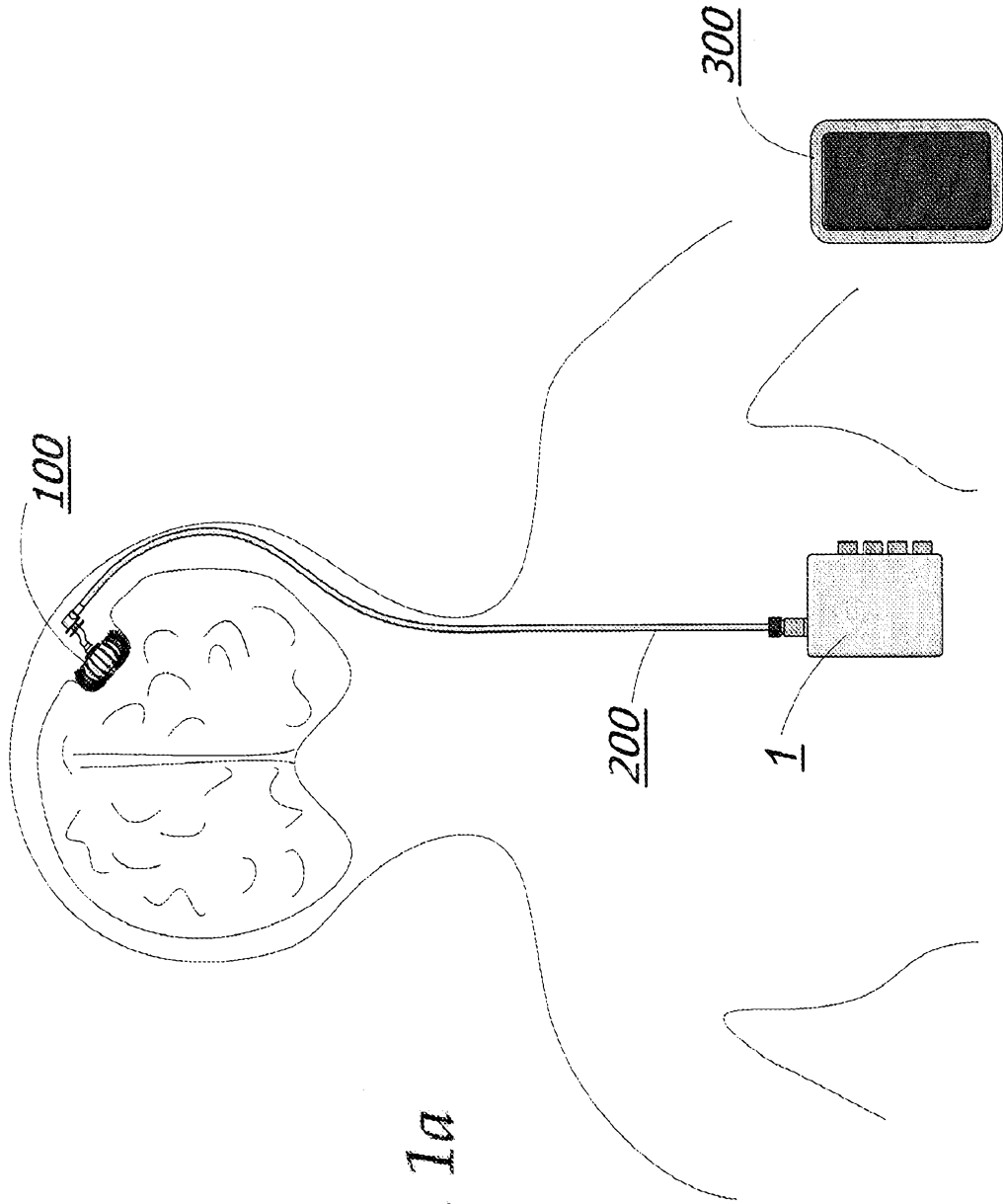

FIG. 1a

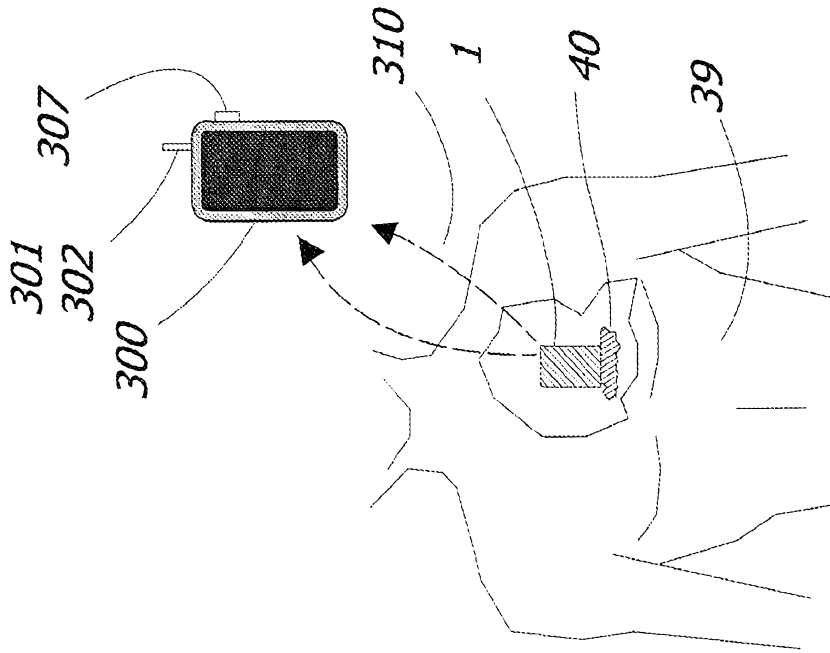

FIG. 1c

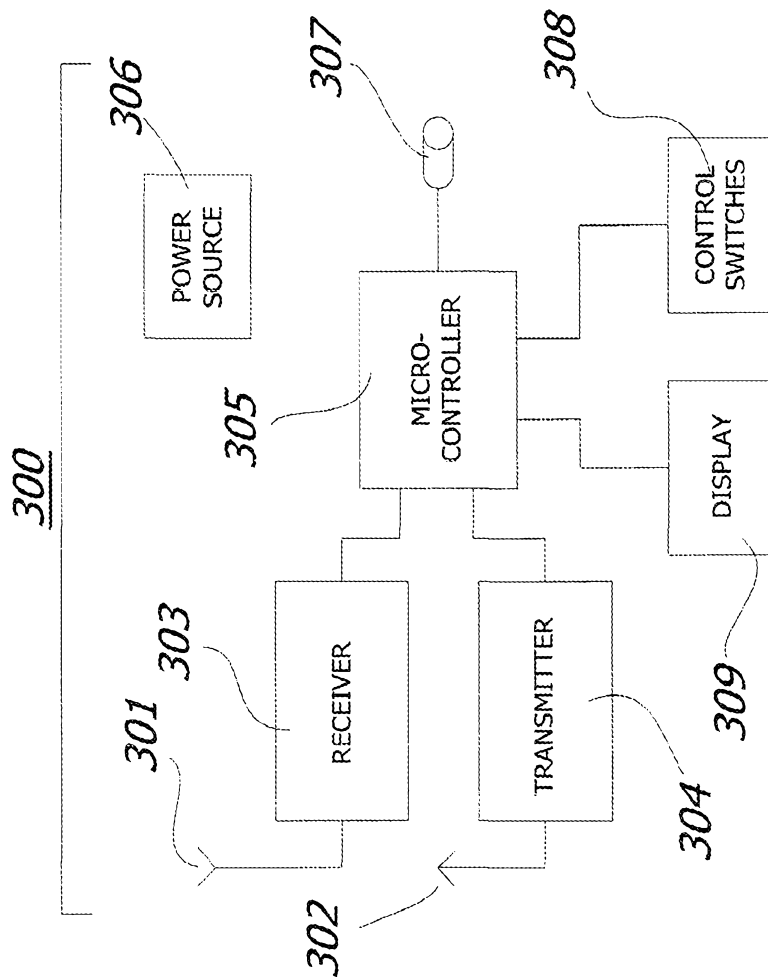

FIG. 1b



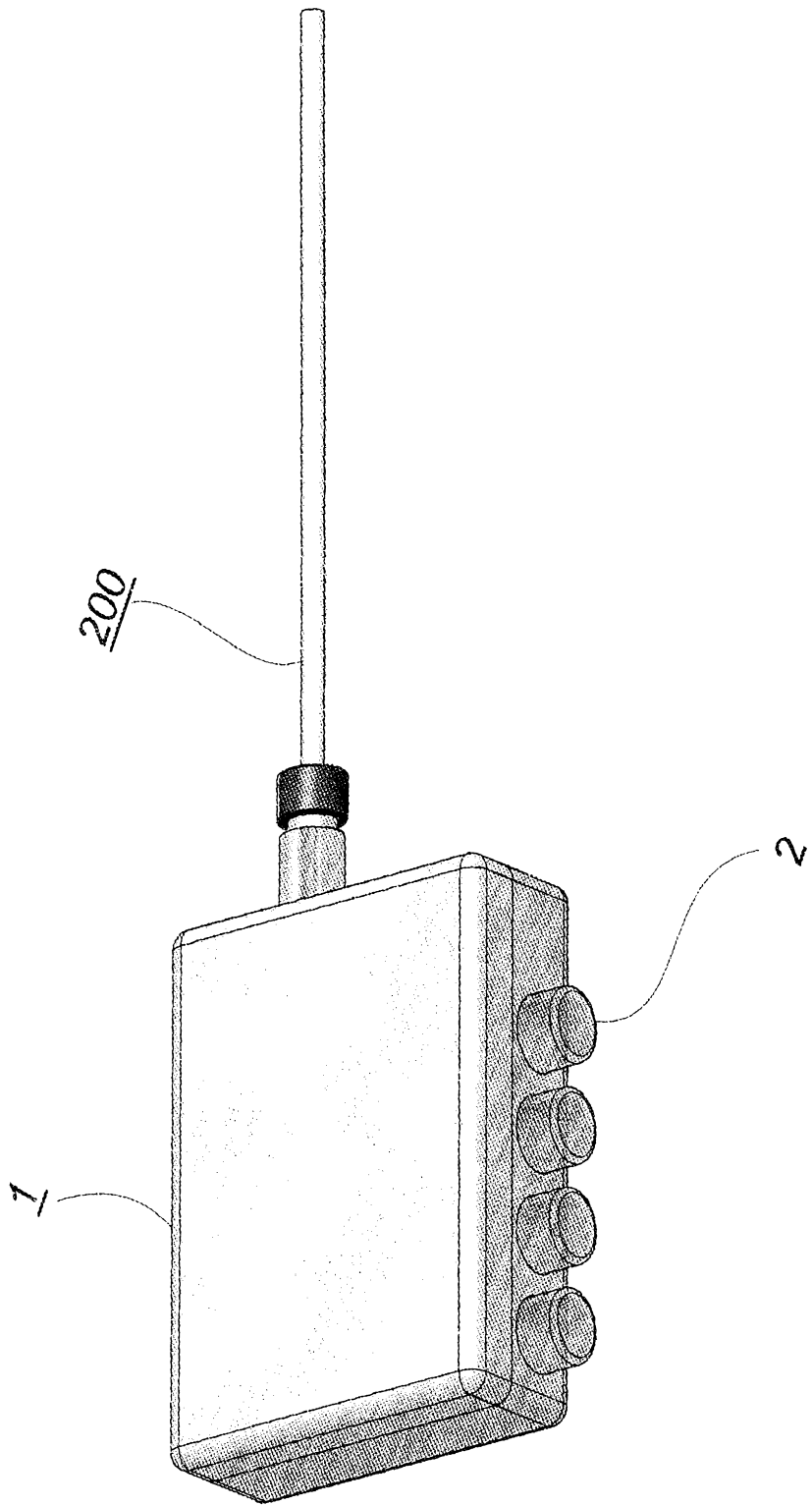

FIG. 2

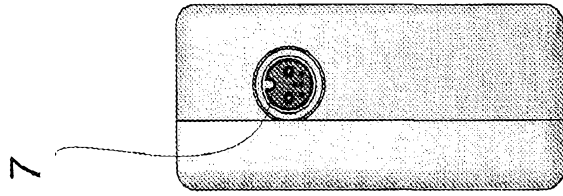

FIG. 3c

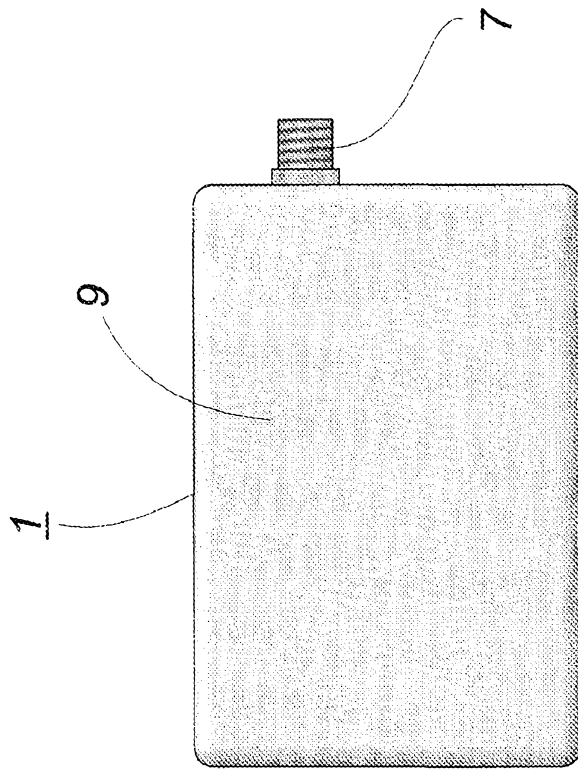

FIG. 3a

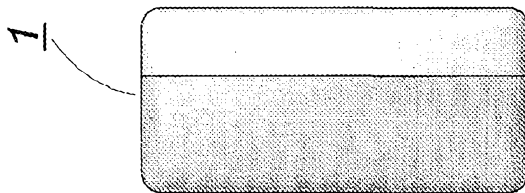

FIG. 3b

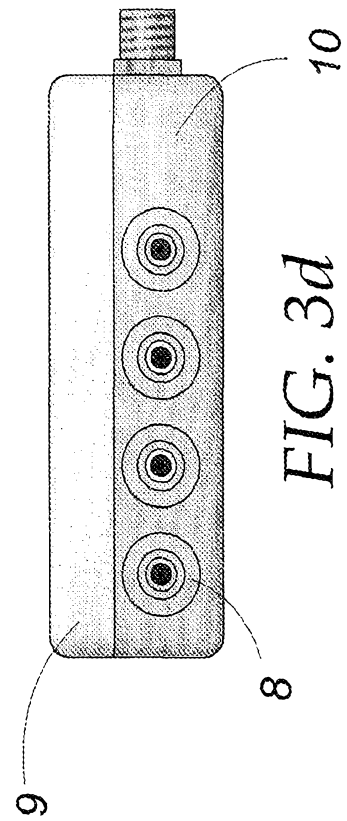

FIG. 3d

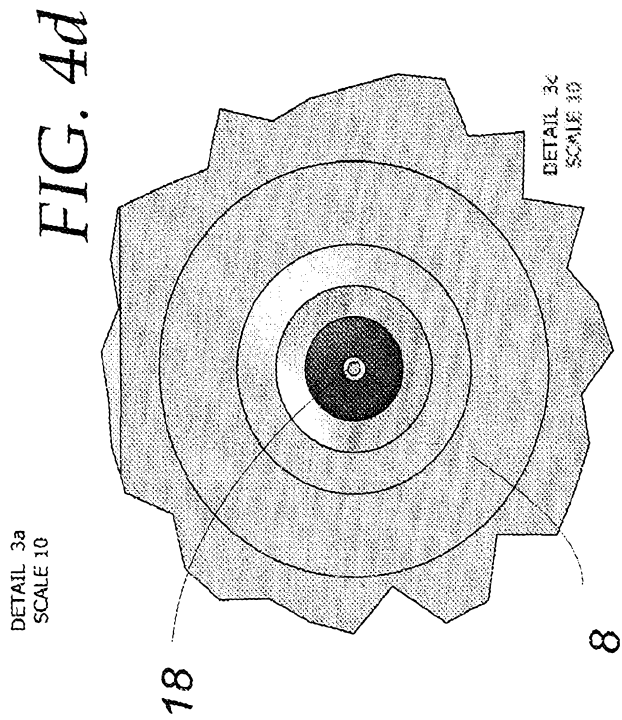
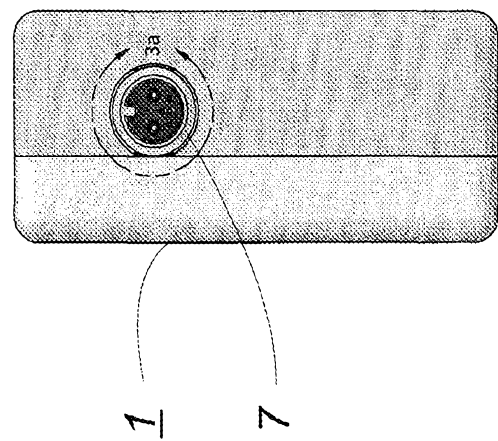
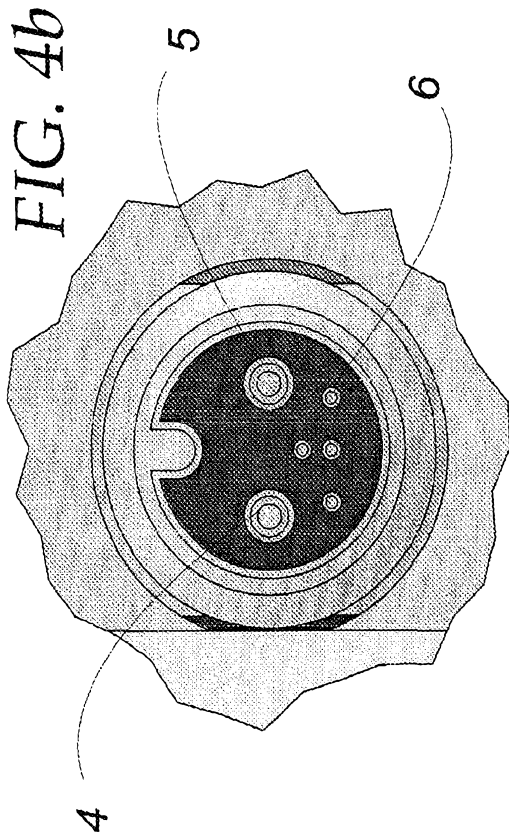

FIG. 4a

FIG. 4d

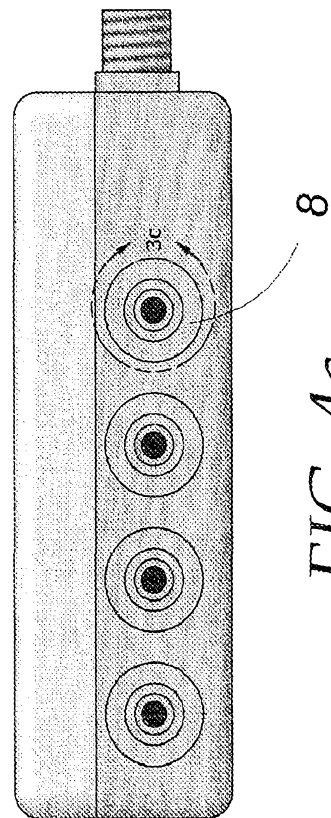

FIG. 4c

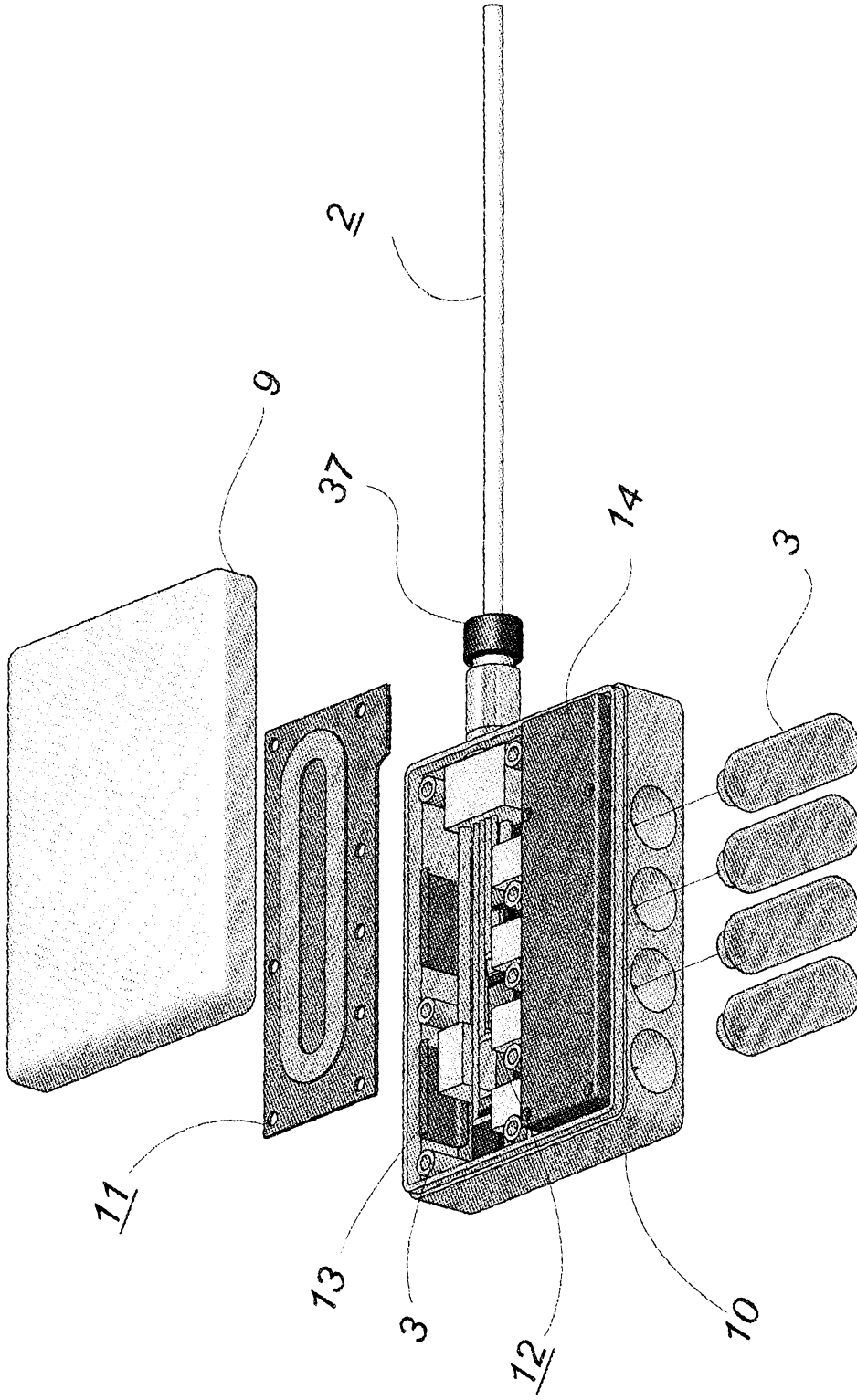

FIG. 5

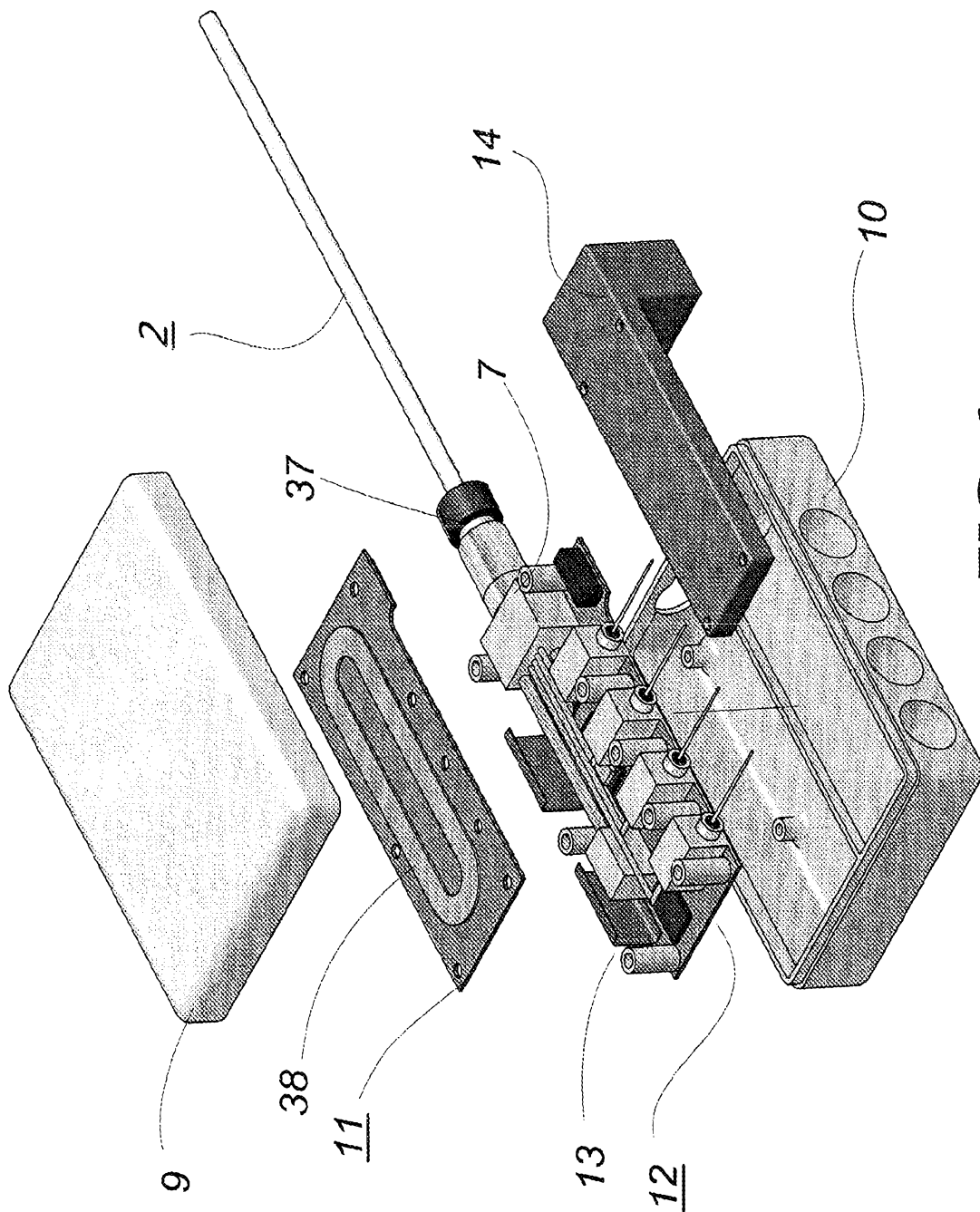
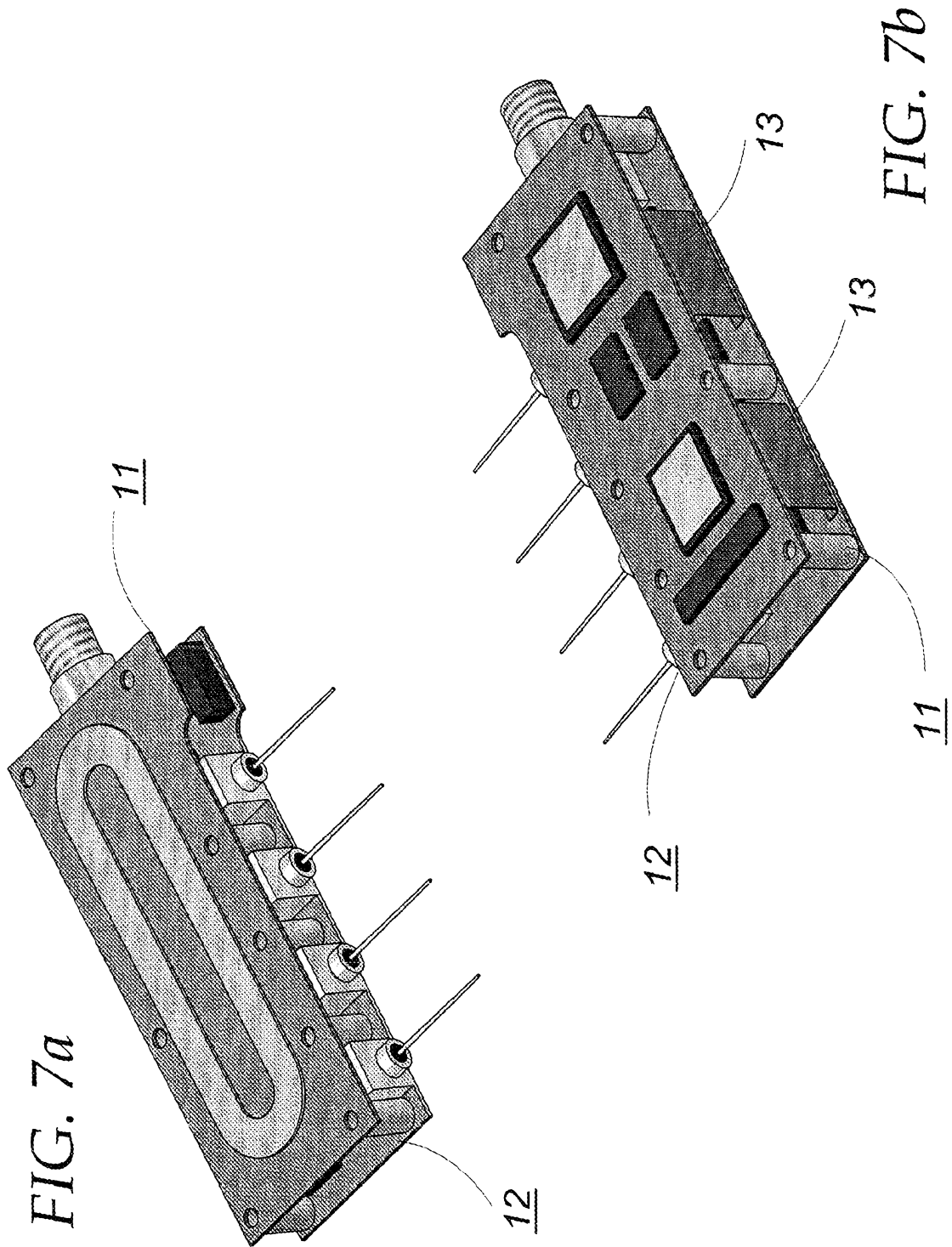

FIG. 6



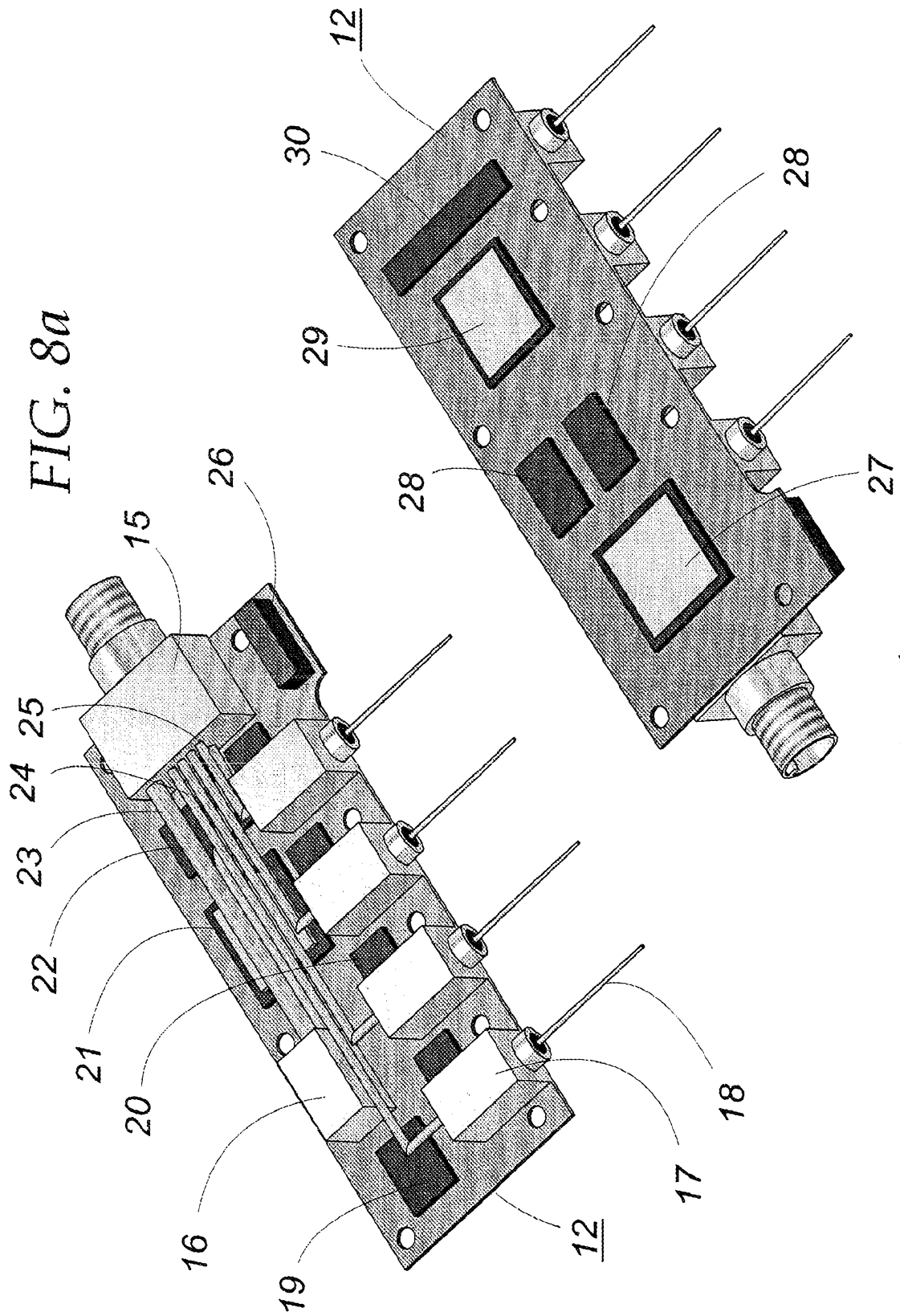

FIG. 8a

FIG. 8b

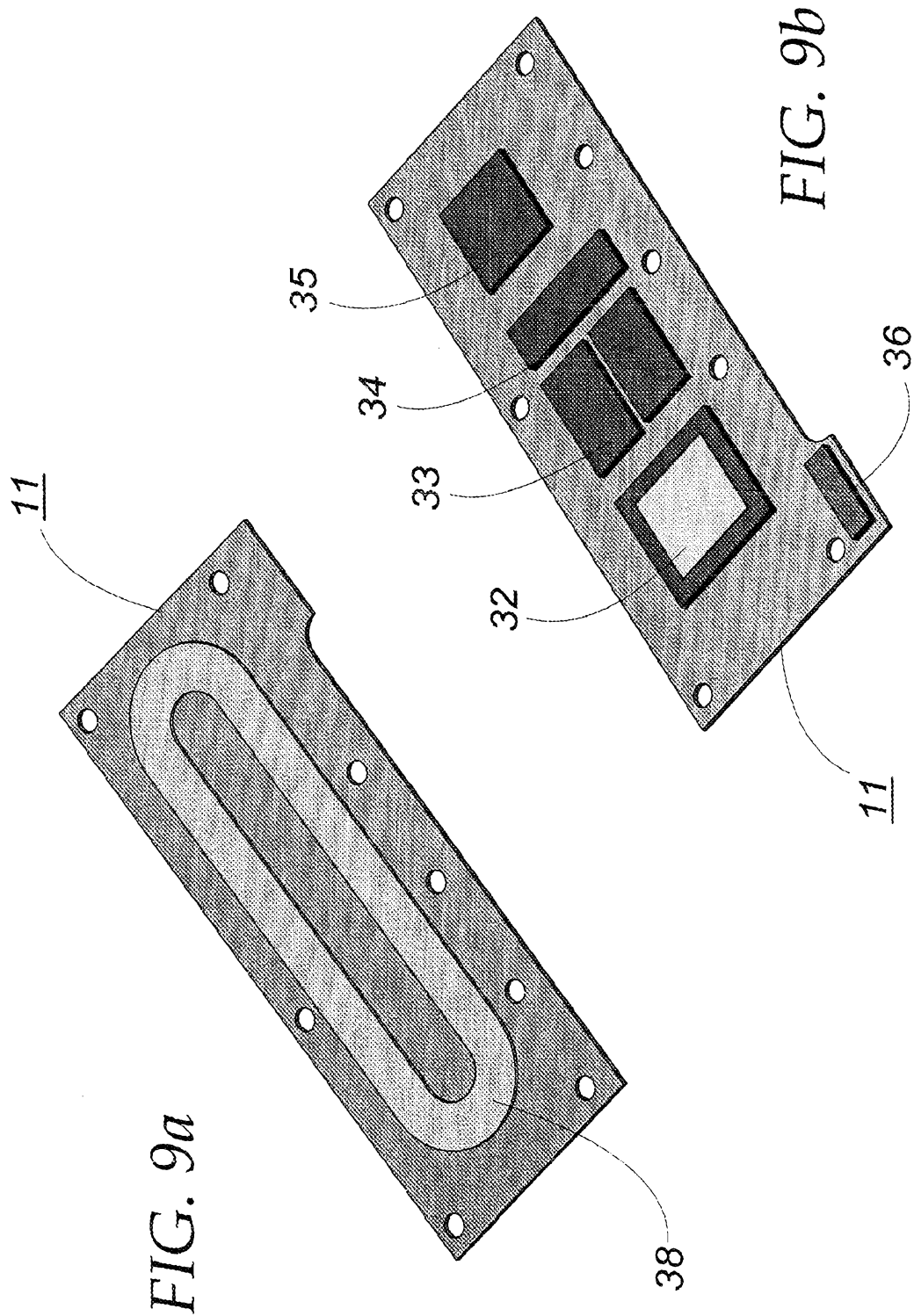

FIG. 9a

FIG. 9b



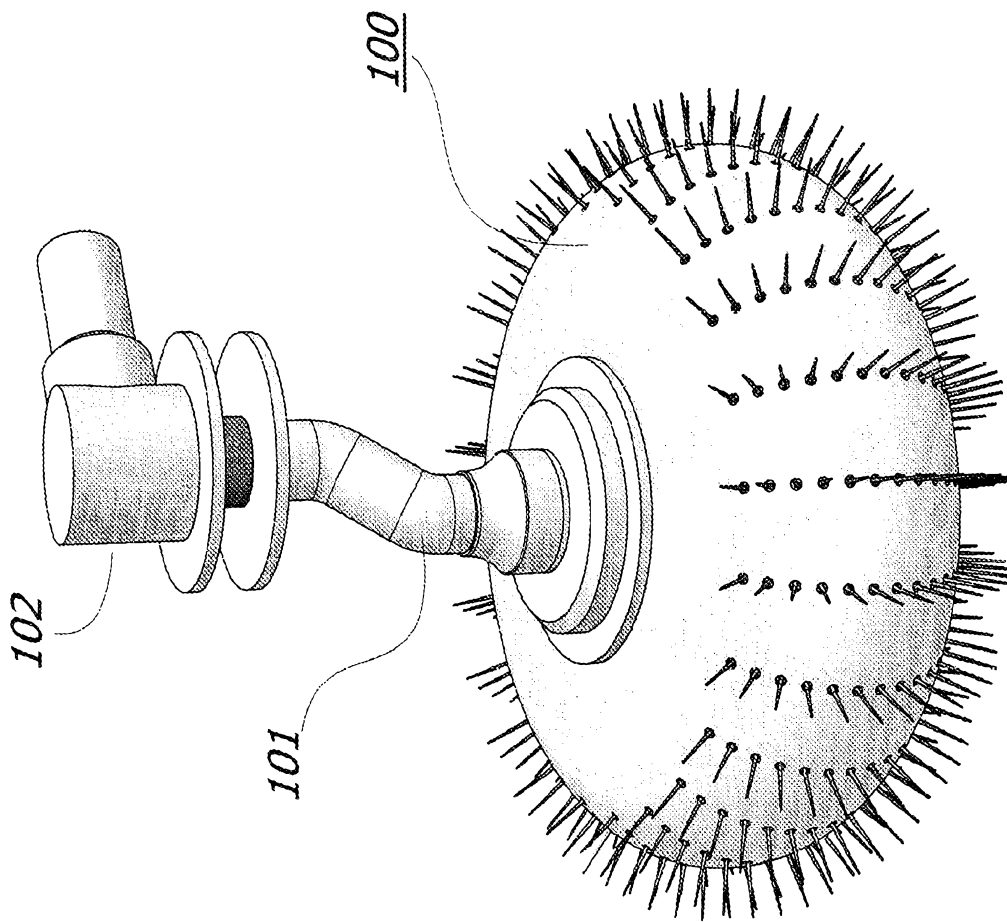

FIG. 10a

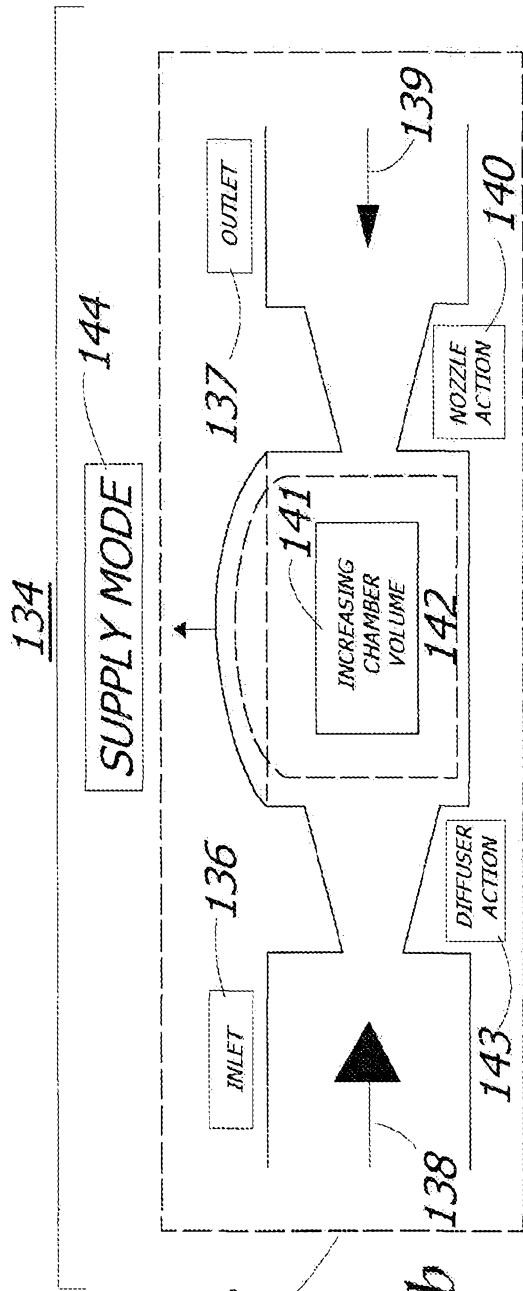

FIG. 10b

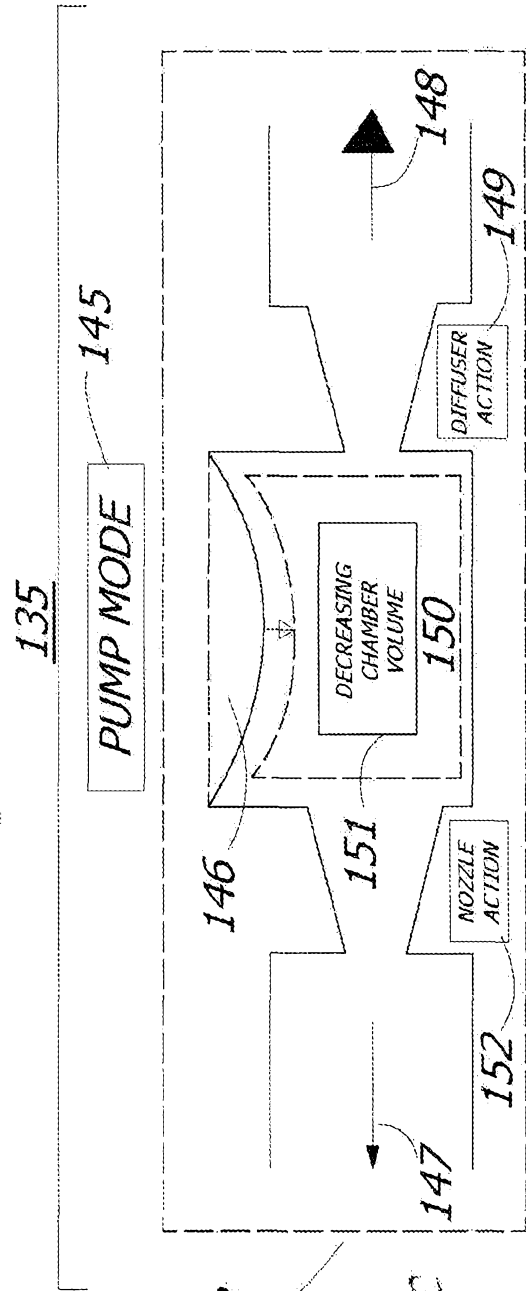

FIG. 10c

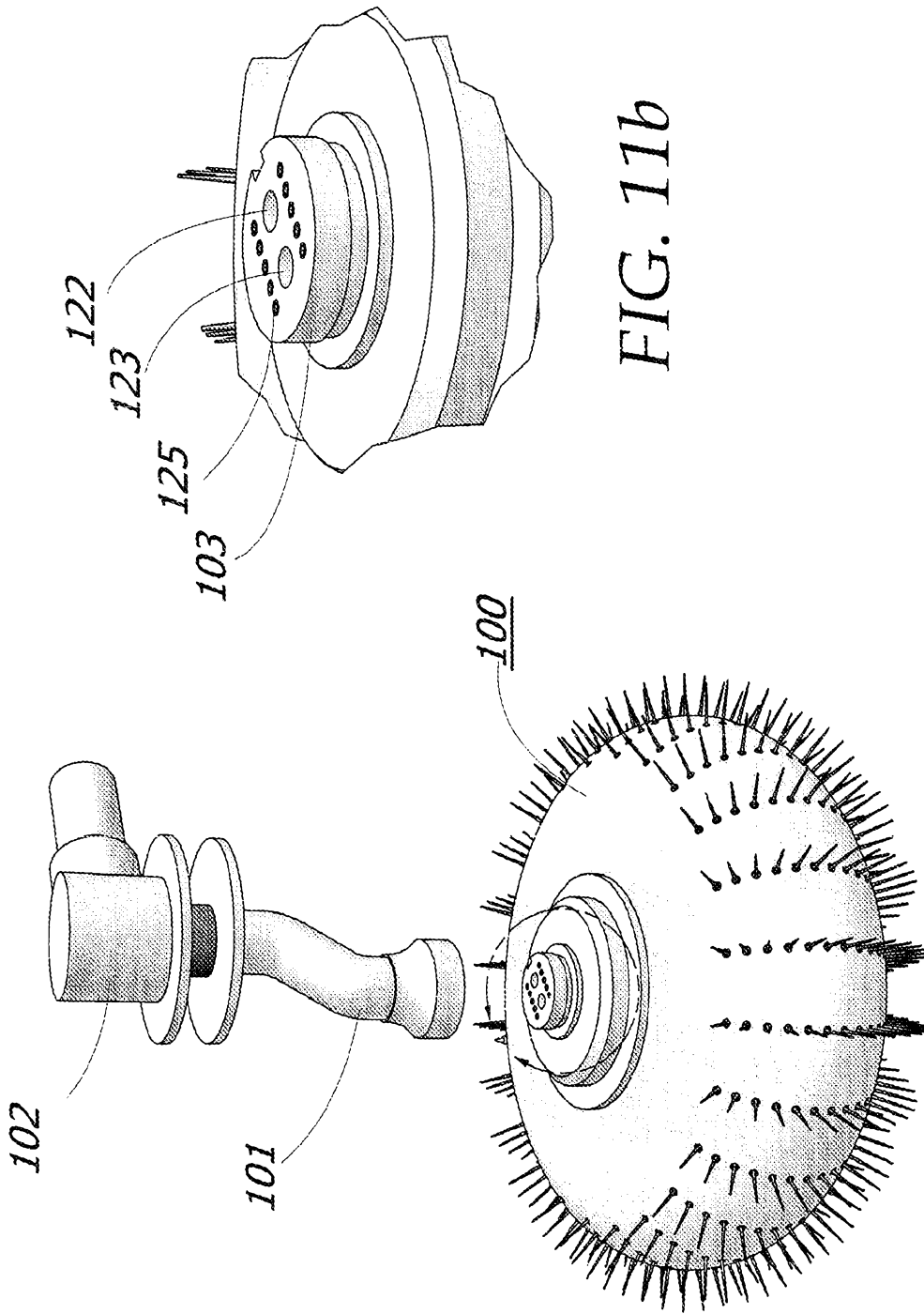

FIG. 11b

FIG. 11a

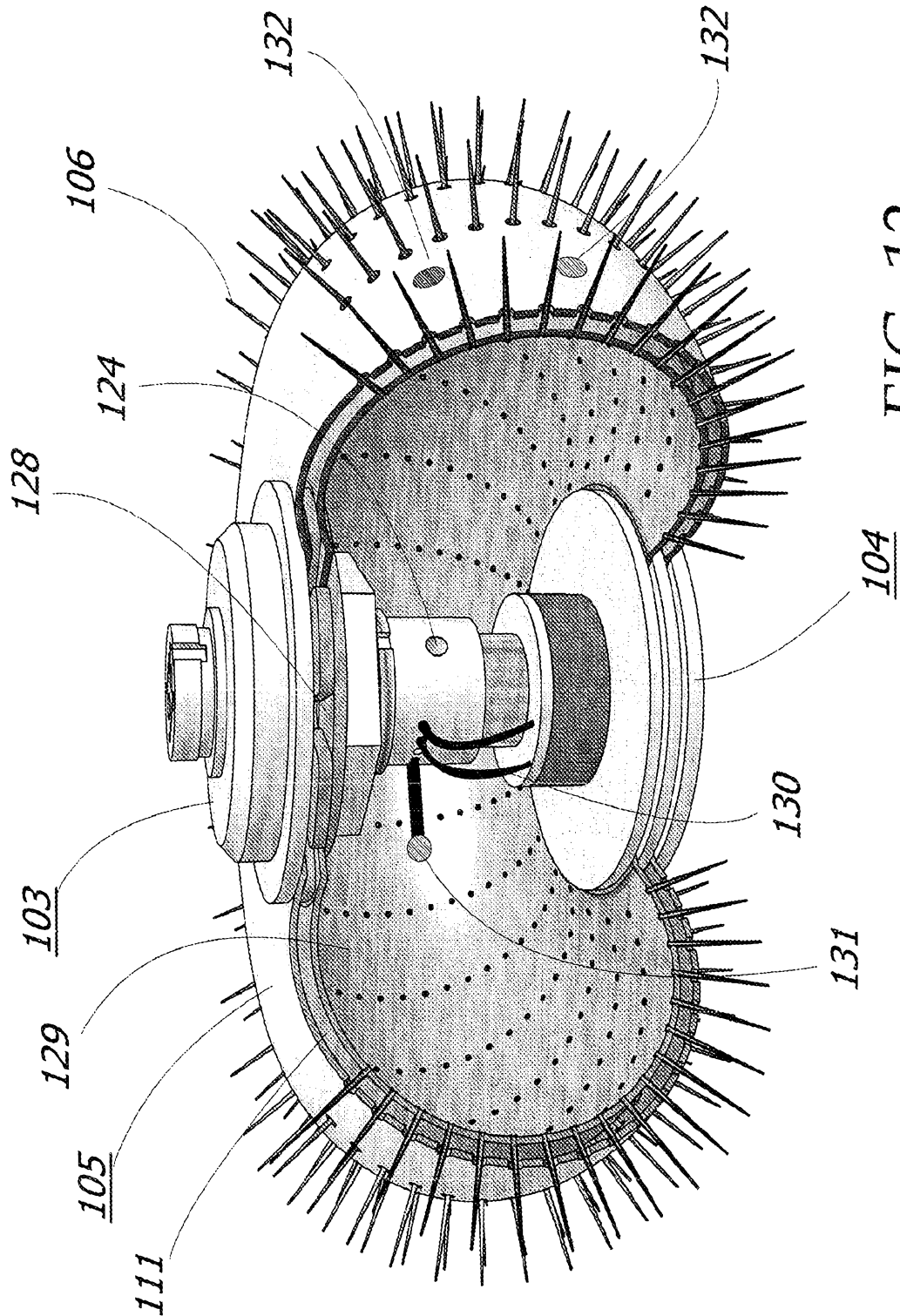

FIG. 12

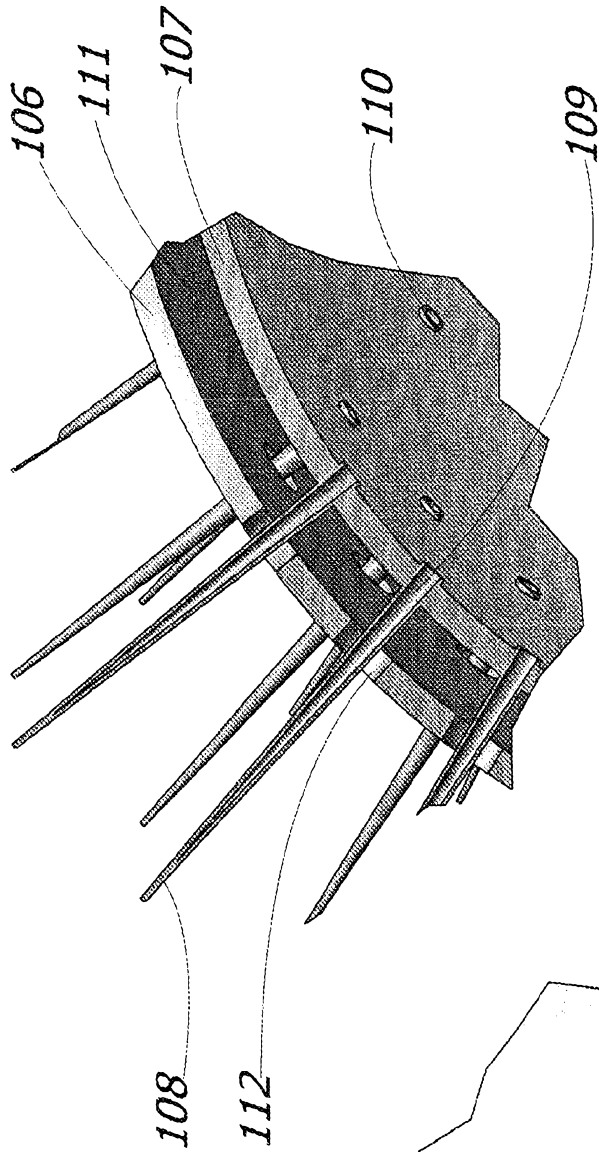

FIG. 13c

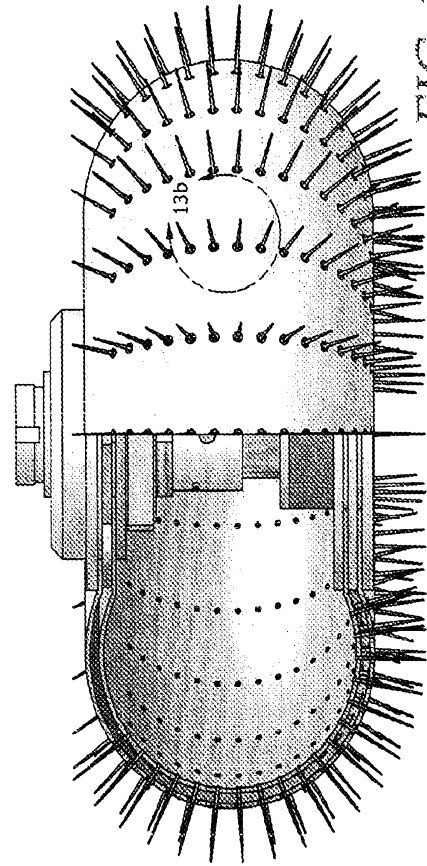

FIG. 13a

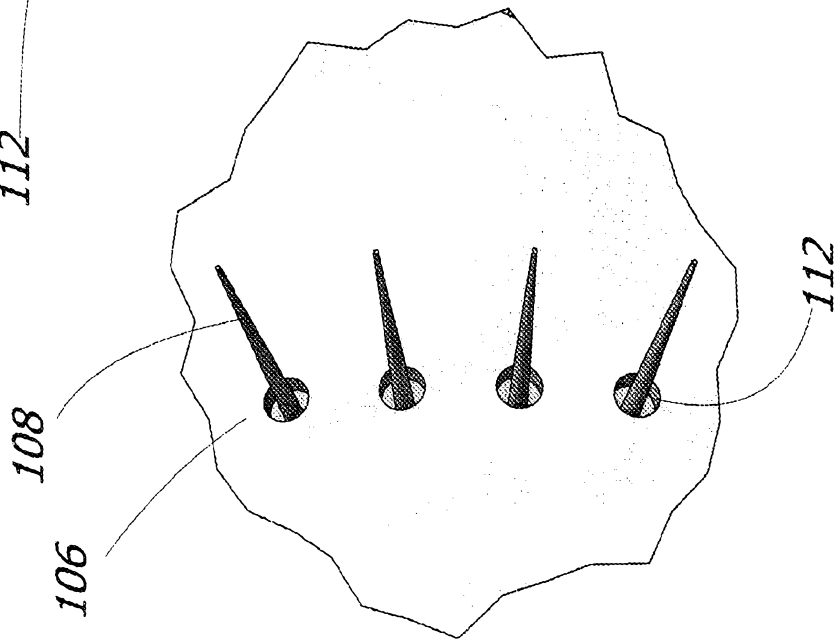

FIG. 13b

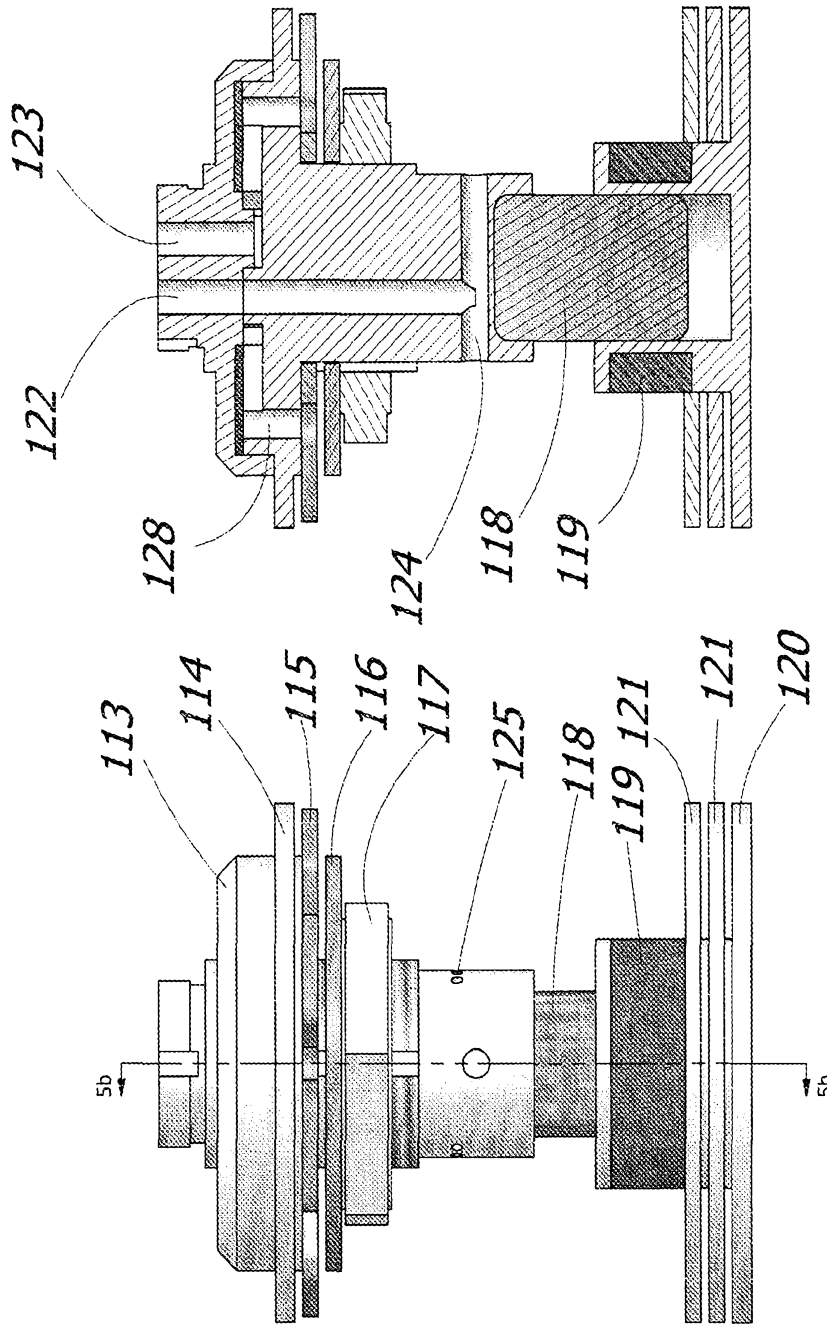

FIG. 15b

FIG. 15a

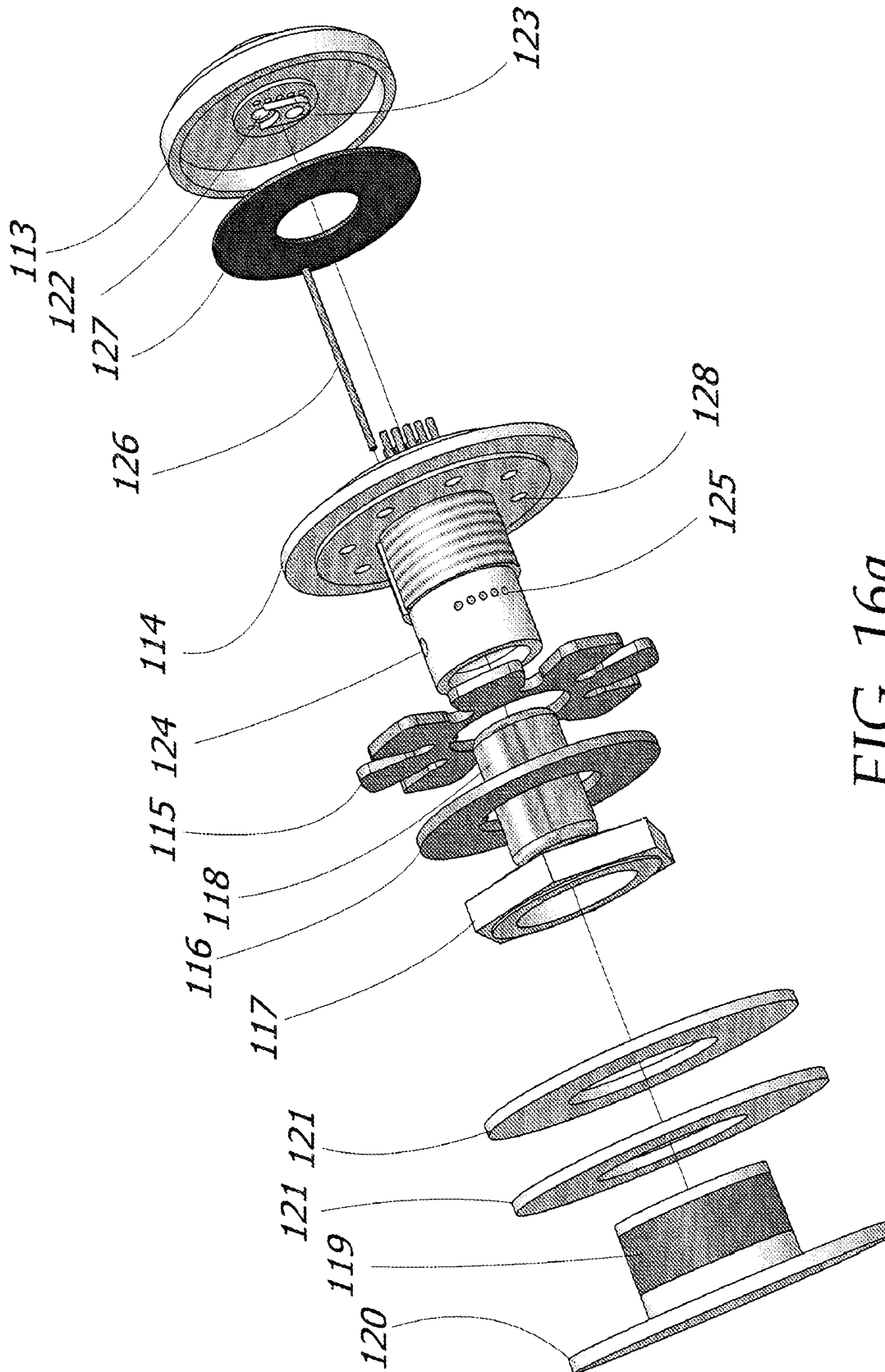

FIG. 16a

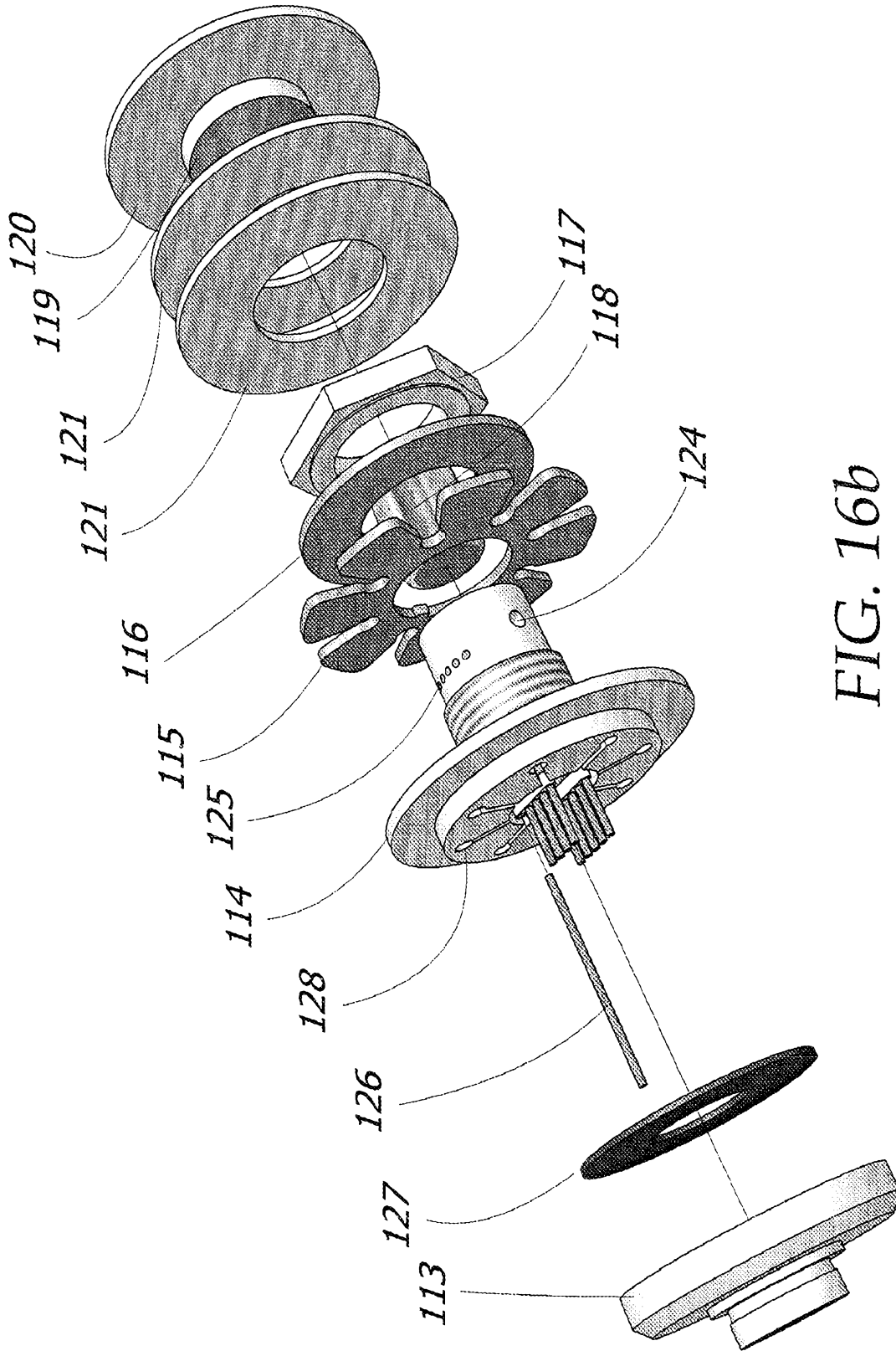

FIG. 16b



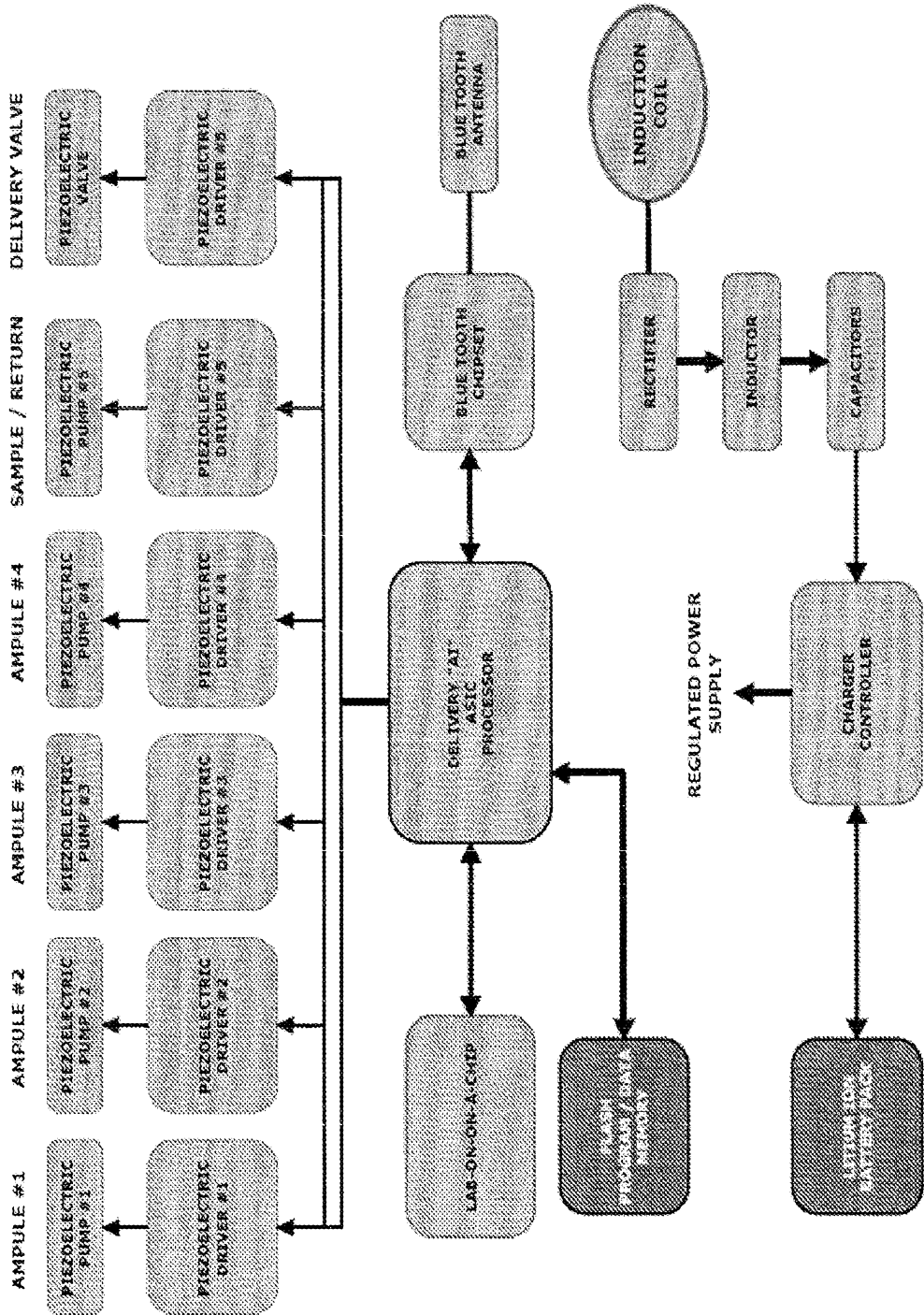

FIG. 17