

(19) World Intellectual Property Organization
International Bureau



(43) International Publication Date
12 May 2011 (12.05.2011)

(10) International Publication Number
WO 2011/057289 A2

- (51) **International Patent Classification:**
A61B 18/14 (2006.01) A61N 1/04 (2006.01)
- (21) **International Application Number:** PCT/US2010/056069
- (22) **International Filing Date:** 9 November 2010 (09.11.2010)
- (25) **Filing Language:** English
- (26) **Publication Language:** English
- (30) **Priority Data:** 12/615,176 9 November 2009 (09.11.2009) US
- (71) **Applicant (for all designated States except US):** MAGNETECS, INC. [US/US]; 10524 S. La Cienega Boulevard, Inglewood, CA 90304 (US).
- (72) **Inventors:** SHACHAR, Yehoshua; 2417 22nd Street, Santa Monica, CA 90405 (US). MARX, Bruce; 1233 Avila Drive, Ojai, CA 93023 (US). JOHNSON, David; 8450 Delongpre Avenue, #6, West Hollywood, CA 90069 (US). FARKAS, Leslie; 254 N. Arnaz Street, Ojai, CA 93023 (US).
- (74) **Agent:** DELANEY, Karoline, A.; Knobbe, Martens, Olson & Bear, LLP, 2040 Main Street, 14th Floor, Irvine, CA 92614 (US).
- (81) **Designated States (unless otherwise indicated, for every kind of national protection available):** AE, AG, AL, AM, AO, AT, AU, AZ, BA, BB, BG, BH, BR, BW, BY, BZ, CA, CH, CL, CN, CO, CR, CU, CZ, DE, DK, DM, DO, DZ, EC, EE, EG, ES, FI, GB, GD, GE, GH, GM, GT, HN, HR, HU, ID, IL, IN, IS, JP, KE, KG, KM, KN, KP, KR, KZ, LA, LC, LK, LR, LS, LT, LU, LY, MA, MD, ME, MG, MK, MN, MW, MX, MY, MZ, NA, NG, NI, NO, NZ, OM, PE, PG, PH, PL, PT, RO, RS, RU, SC, SD, SE, SG, SK, SL, SM, ST, SV, SY, TH, TJ, TM, TN, TR, TT, TZ, UA, UG, US, UZ, VC, VN, ZA, ZM, ZW.
- (84) **Designated States (unless otherwise indicated, for every kind of regional protection available):** ARIPO (BW, GH, GM, KE, LR, LS, MW, MZ, NA, SD, SL, SZ, TZ, UG, ZM, ZW), Eurasian (AM, AZ, BY, KG, KZ, MD, RU, TJ, TM), European (AL, AT, BE, BG, CH, CY, CZ, DE, DK,

[Continued on next page]

(54) **Title:** SYSTEM AND METHOD FOR TARGETING CATHETER ELECTRODES

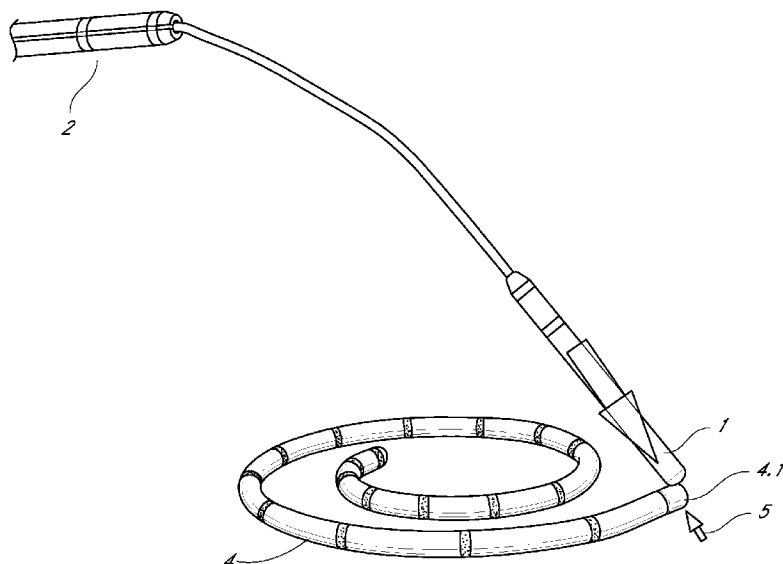

FIG. 3

(57) **Abstract:** A system and method is described for a catheter guidance system which allows an operator to use a mapping catheter to specify tissue target locations for the automatic guidance of a second therapeutic catheter. The operator places a mapping catheter at a desired location, and commands the catheter guidance system by either selecting a point on that catheter or one of the catheter electrode electrocardiograms. The operator may target the selected dynamic location, or tissue contact beyond that location on a specific side of the mapping catheter.



WO 2011/057289 A2

EE, ES, FI, FR, GB, GR, HR, HU, IE, IS, IT, LT, LU, LV, MC, MK, MT, NL, NO, PL, PT, RO, RS, SE, SI, SK, SM, TR), OAPI (BF, BJ, CF, CG, CI, CM, GA, GN, GQ, GW, ML, MR, NE, SN, TD, TG). **Published:** — *without international search report and to be republished upon receipt of that report (Rule 48.2(g))*

SYSTEM AND METHOD FOR TARGETING CATHETER ELECTRODES

Background

Field of the Invention

[0001] The invention relates to the systems and methods for guiding, steering and advancing an invasive medical device in a patient.

Description of the Related Art

[0002] In cardiac electrophysiological procedures, mapping catheters are used to define the geometry of a coronary chamber and map its surface electrocardiogram. Mapping catheters contain an array of electrodes which are used for position location and sensing the surface electrical activity. For sensing electrical activity, these electrodes are either used individually or in differential pairs, depending upon the type of sensory hardware available. When the surface has been fully mapped, a mapping catheter is often used in conjunction with an ablation catheter to locate and deliver therapeutic treatment at specific locations. The mapping catheter is returned to the area of interest, and the electrogram at each electrode or electrode pair is observed on the data recorder to determine the precise location along the mapping catheter for treatment. The ablation catheter is then guided independently to that location to deliver radiofrequency energy. Unfortunately, mapping of the heart chamber using prior art systems is a time-consuming process that increases the cost and risk of ablation procedures. The mapping process is complicated by the fact that the walls of a beating heart, not stationary, and the surgeon using traditional mapping catheters, does not have adequate control of the distal end of the catheter.

Summary

[0003] The system and method described herein solve these and other problems by incorporating algorithms in a catheter guidance and control system that allows the operator to specify a target location as either a mapping catheter electrode, another location on the mapping catheter, or a mapping catheter electrode electrogram. The mapping process includes moving a catheter about a coronary chamber to define the

average location of the walls and the electrical activity of the nerves within those walls during the heartbeat cycle.

[0004] The catheter guidance system then uses this live moving location to guide the therapeutic ablation catheter to this location or to tissue contact (e.g., where the tip of the catheter maintains relatively continuous contact with the surface of the heart chamber wall throughout the heartbeat cycle) near this location. This is done to increase the accuracy of targeting tissue contact at the location which is not possible with the targeting of a static geometric map. In one embodiment, the moving location corresponds to a Cartesian point on a geometric map which represents the average position of the tissue location that passes through that point.

[0005] In one embodiment, a spiral mapping catheter is manually positioned against the tissue surface. In one embodiment, a spiral mapping catheter includes a type of mapping catheter with a plurality of electrodes arranged along its coiled distal end. In one embodiment, the spiral mapping catheter can include five or more electrodes, ten or more electrodes, twenty or more electrodes, 50 or more electrodes, etc. In one embodiment, one or more of the electrodes involve a conductive ring on the catheter. The electrodes can be wired through the catheter line to the position detection and heart electrogram sensing hardware.

[0006] Manual controls are provided to adjust the amount of coil to make it larger or smaller, as well as to bend the assembly back and forth during the manual mapping process.

[0007] A magnetically-guided ablation catheter is introduced into the chamber to be used to deliver therapeutic energy. The an ablation catheter can be used in an ablation procedure to apply energy (e.g., radio frequency electrical) to a specific location within the heart is to necrotize (kill) tissue and block neural conduction pathways as to eliminate electrical signals that are the cause of cardiac arrhythmias. In a magnetic guidance system, a magnet (either a permanent magnet and/or an electromagnet) is provided to the distal end of the catheter and the distal end is then guided into position by a system of electromagnets external to the patient.

[0008] The catheter guidance control and imaging system is given the location of the distal electrode of the spiral mapping catheter as the desired position for the distal tip of the ablation catheter. The catheter guidance control and imaging system moves the ablation catheter distal tip into contact with the distal electrode of the spiral

catheter. As the spiral catheter electrode moves, the catheter guidance system adjusts the ablation catheter location to maintain contact with that electrode.

[0009] In one embodiment, the catheter guidance control and imaging system moves the catheter tip into contact with the distal electrode of the spiral catheter and then moves the distal tip of the catheter past the spiral catheter electrode until continuous contact is made between the catheter tip and the chamber wall.

[0010] In one embodiment, the operator selects the target electrode on the spiral catheter by positioning the mouse cursor over the electrode and double-clicking the left mouse button. The catheter guidance and control system continuously sends this electrode's live position as a target position for automatic guidance to automatically advance, steer and/or push a catheter toward a desired position.

[0011] In one embodiment, the operator selects the target electrode on the spiral catheter by positioning the mouse cursor over the electrode's electrogram trace and double-clicking the left mouse button. The associated electrode's live position is used as target for automatic guidance.

[0012] In one embodiment, the operator selects a target electrode pair on the spiral catheter by selecting the electrode pair's electrogram trace. The catheter guidance and control system continuously sends the average position of the electrode pair as the desired position.

[0013] In one embodiment, the operator selects a location between electrodes by positioning the mouse cursor over a location on the mapping catheter and double-clicking the mouse button. The catheter guidance and control system continuously sends an interpolated position between the adjacent electrode pairs as the desired position.

[0014] In one embodiment, the operator may target tissue contact on a specific side of a mapping catheter by selecting a side preference cursor which appears when the mouse cursor is in close proximity to the mapping catheter.

[0015] In one embodiment, catheter guidance includes introducing a mapping catheter into a patient, moving the mapping catheter within the patient to bring an electrode provided to the mapping catheter in contact with tissues at various locations to generate a desired map, identifying a target location from the map and placing an electrode of the mapping catheter proximate to the target location, introducing a therapeutic catheter into the patient and guiding the therapeutic catheter to a location of the electrode. In one embodiment, the therapeutic catheter is moved past the location of

the electrode. In one embodiment, the mapping catheter is guided using magnetic fields. In one embodiment, the therapeutic catheter is guided using magnetic fields.

[0016] One embodiment includes a system for catheter guidance having a mapping catheter having at least one electrode proximate to a distal end of the mapping catheter, therapeutic catheter, a first catheter guidance and control system that moves the mapping catheter to bring the at least one electrode in contact with tissues at various locations to generate a desired map, and a second catheter guidance and control system that moves a distal end portion of the therapeutic catheter to a location of the at least one electrode. In one embodiment, the therapeutic catheter includes an ablation catheter. In one embodiment, the second catheter guidance and control system includes a magnetic guidance and control system that uses a plurality of electromagnets to control a position of a magnet provided to a distal end of the therapeutic catheter. In one embodiment, the first catheter guidance and control system comprises a magnetic guidance and control system that uses a plurality of electromagnets to control a position of a magnet provided to a distal end of the mapping catheter. In one embodiment, the second catheter guidance and control system automatically moves a distal end portion of the therapeutic catheter to a location of the at least one electrode

Brief Description of the Drawings

[0017] Figure 1 is an illustration of an ablation catheter, spiral catheter and the catheter guidance and control elements.

[0018] Figure 2 is an illustration of a set of catheter electrode electrogram traces.

[0019] Figure 3 is an illustration of an ablation catheter in contact with a spiral catheter electrode.

[0020] Figure 4 is an illustration of an ablation catheter tip moving beyond a spiral catheter electrode in order to acquire tissue contact near that electrode.

Detailed Description

[0021] Figure 1 shows a distal end of a spiral mapping catheter 4 and a distal end of an ablation catheter 1. The mapping catheter 4 includes a plurality of electrodes including an electrode 4.1 disposed at or near the distal end of the catheter 4, an electrode

4.2 disposed at a position on the catheter 4 less distal than the electrode 4.1, etc. The ablation catheter 1 is introduced into a coronary chamber via a sheath (or introducer) 2. The sheath (or introducer) 2 includes a tube which is inserted through a vein or other pathway or orifice into the heart. Catheters, wires and/or fluids can be introduced into the heart chamber through this tube.

[0022] In one embodiment, the tip of the ablation catheter 1 contains a magnetically-doped core element and sensory electrodes. The magnetic indicator 3 displays the current direction of the magnetic field that is guiding the catheter tip. A spiral mapping catheter 4 is introduced into the chamber and manually guided by levers on its handle (e.g., at the proximal end, not shown) to a desired location. The operator uses a mouse cursor 5 to double-click on a representation of the distal electrode 4.1 of the spiral catheter 4 to command the catheter guidance control and imaging system to guide the ablation catheter 1 to the spiral catheter electrode 4.1. The operator may also select any location between locations, such as between the distal 4.1 and second electrode 4.2 and a linearly interpolated position will be sent to the catheter guidance control and imaging system.

[0023] Figure 2 is an illustration of a set of catheter electrode electrogram traces 6. In one embodiment, the electrogram configured as a time versus amplitude plot of the electrical potential as measured at a specific point on, or in the body. Electrograms for each electrode pair can be displayed on the mapping system and/or on a separate ECG system.

[0024] Alternately to the process described in Figure 1, the operator can use the mouse to double-click on a spiral mapping catheter's electrogram trace to command the catheter guidance, control and imaging system to guide the ablation catheter to that spiral catheter electrode or electrode pair. In this alternate embodiment, the operator selects the distal pair of spiral catheter electrodes 6.1 and the ablation catheter is guided to an average location between the distal electrode 4.1 and second electrode 4.2.

[0025] Figure 3 shows the ablation catheter 1 in contact with a spiral catheter electrode where the ablation catheter 1 has been guided into contact with the spiral mapping catheter's distal electrode 4.1. The live electrode position of the catheter tip and the live electrode position of the distal spiral catheter electrode can be continuously synchronized by the catheter guidance and control system.

[0026] Figure 4 shows the ablation catheter 1 moving beyond the spiral catheter electrode 4.1 in order to acquire tissue contact near that electrode. The operator has elected to automatically guide the ablation catheter 1 past the spiral catheter distal electrode 4.1 until tissue contact is made on the outside of the spiral catheter 4. The operator has used the side preference cursor 7 to select the side preference which moved the desired position that side of the spiral catheter electrode 4.1.

[0027] The words used in this specification to describe the invention and its various embodiments are to be understood not only in the sense of their commonly defined meanings, but to include by special definition in this specification structure, material or acts beyond the scope of the commonly defined meanings. Thus, if an element can be understood in the context of this specification as including more than one meaning, then its use in a claim must be understood as being generic to all possible meanings supported by the specification and by the word itself.

[0028] The claims are thus to be understood to include what is specifically illustrated and described above, what is conceptually equivalent, what can be obviously substituted and also what essentially incorporates the essential idea of the invention.

[0029] It is to be understood that the illustrated embodiment has been set forth only for the purposes of example and that it should not be taken as limiting the invention as defined by the following claims. For example, notwithstanding the fact that the elements of a claim are set forth below in a certain combination, it must be expressly understood that the invention includes other combinations of fewer, more or different elements, which are disclosed in above even when not initially claimed in such combinations. A teaching that two elements are combined in a claimed combination is further to be understood as also allowing for a claimed combination in which the two elements are not combined with each other, but can be used alone or combined in other combinations. The excision of any disclosed element of the invention is explicitly contemplated as within the scope of the invention.

[0030] Insubstantial changes from the claimed subject matter as viewed by a person with ordinary skill in the art, now known or later devised, are expressly contemplated as being equivalently within the scope of the claims. Therefore, obvious substitutions now or later known to one with ordinary skill in the art are defined to be within the scope of the defined elements. Accordingly, the invention is limited only by the claims.

WHAT IS CLAIMED IS:

1. A method for catheter guidance, comprising:
 - introducing a mapping catheter into a patient;
 - moving said mapping catheter within the patient to bring an electrode provided to said mapping catheter in contact with tissues at various locations to generate a desired map;
 - identifying a target location from said map and placing an electrode of said mapping catheter proximate to said target location; and
 - introducing a therapeutic catheter into the patient and guiding said therapeutic catheter to a location of said electrode of said mapping catheter proximate said target location.

2. The method of Claim 1, further comprising guiding said therapeutic catheter past said location of said electrode.

3. The method of Claim 1, wherein said mapping catheter is guided using magnetic fields.

4. The method of Claim 1, wherein said therapeutic catheter is guided using magnetic fields.

5. A system for catheter guidance, comprising:
 - a mapping catheter having at least one electrode proximate to a distal end of said mapping catheter, wherein the mapping catheter comprises a first catheter guidance and control system that controls at least one electrode disposed at said distal end of said mapping catheter, said mapping catheter configured to contact tissues to generate a desired map, said mapping catheter further configured to place said electrode proximate a target location identified by said map; and
 - a therapeutic catheter comprising a second catheter guidance and control system that positions said therapeutic catheter at said target location based on said location of said electrode of said mapping catheter;

6. The system of Claim 5, wherein said therapeutic catheter comprises an ablation catheter.

7. The system of Claim 5, wherein said second catheter guidance and control system comprises a magnetic guidance and control system that uses a plurality of electromagnets to control a position of a magnet provided to a distal end of said therapeutic catheter.

8. The system of Claim 5, wherein said first catheter guidance and control system comprises a magnetic guidance and control system that uses a plurality of electromagnets to control a position of a magnet provided to a distal end of said mapping catheter.

9. The system of Claim 5, wherein said second catheter guidance and control system automatically moves a distal end portion of said therapeutic catheter to a location of said at least one electrode.

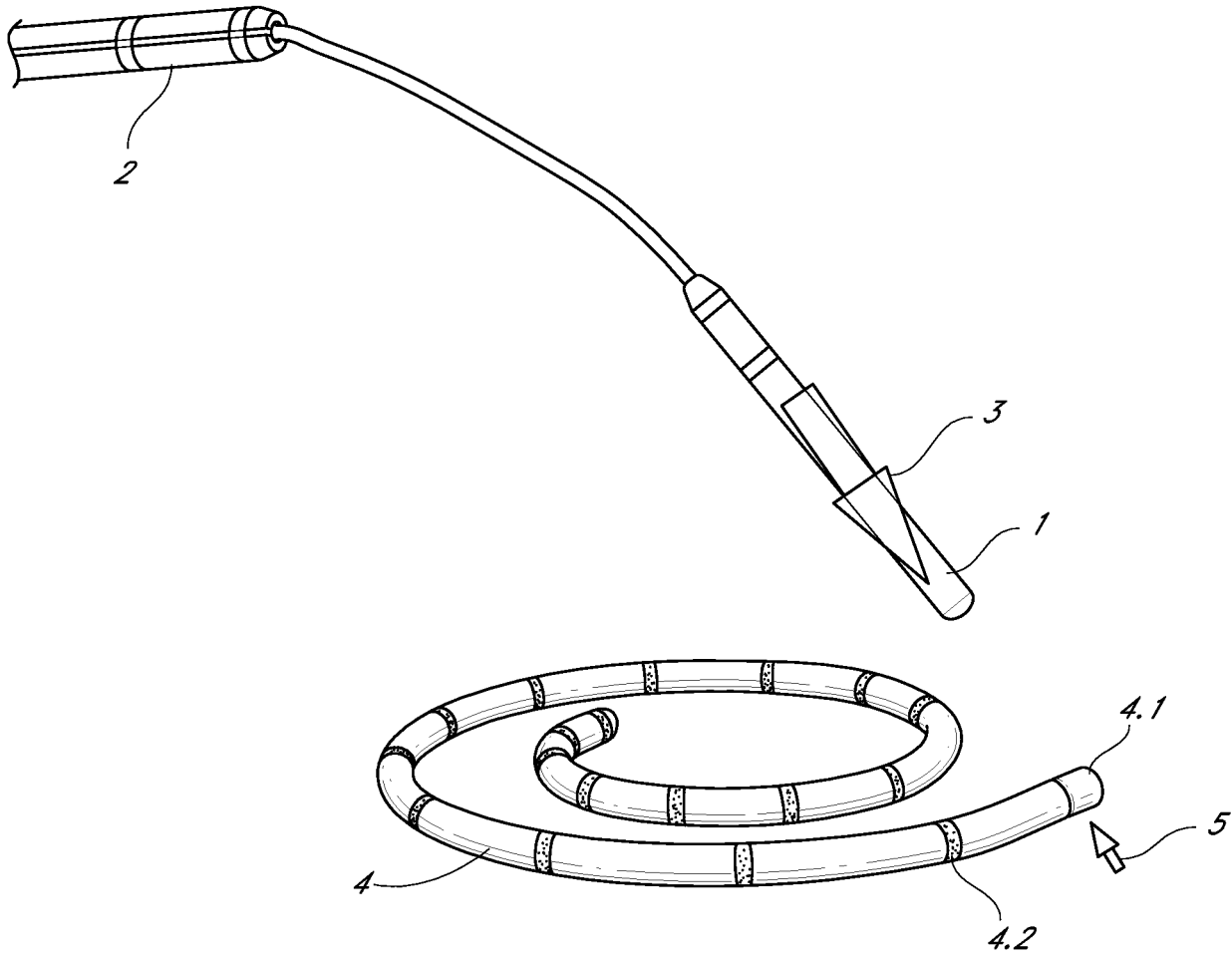

FIG. 1

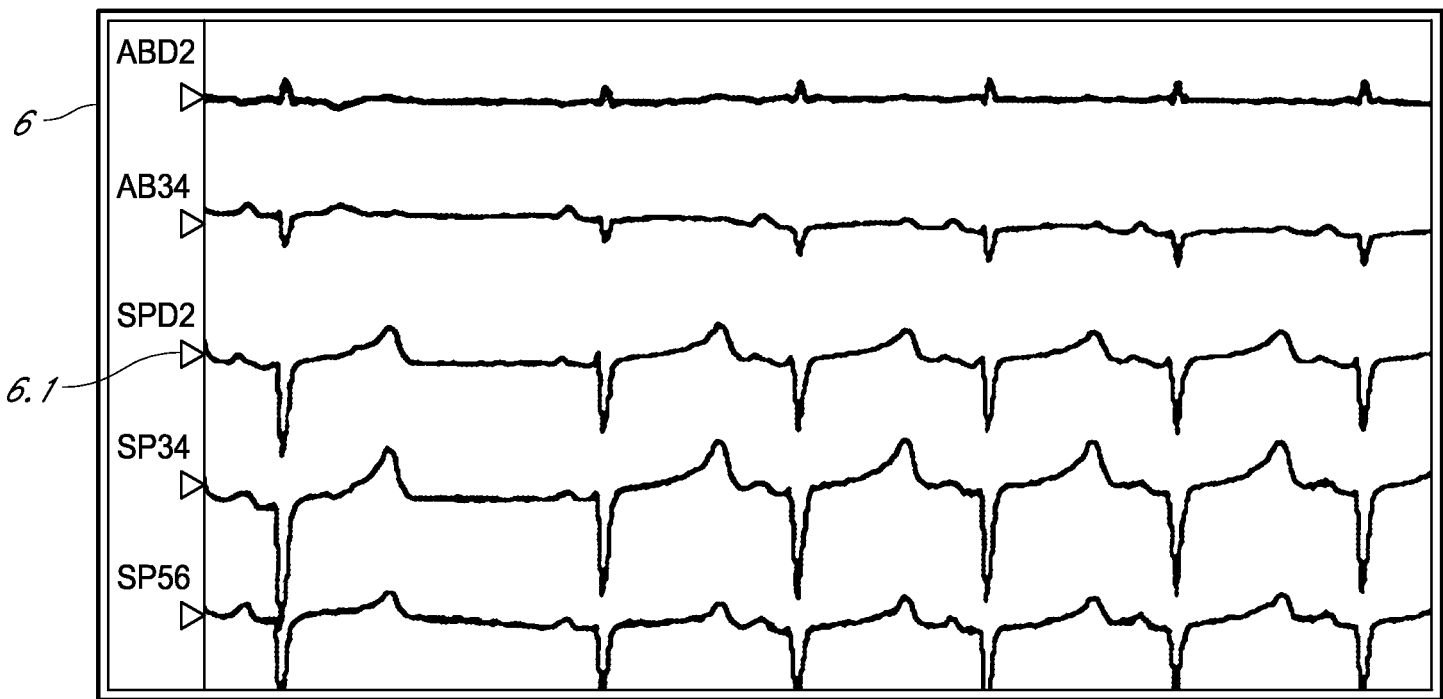

FIG. 2

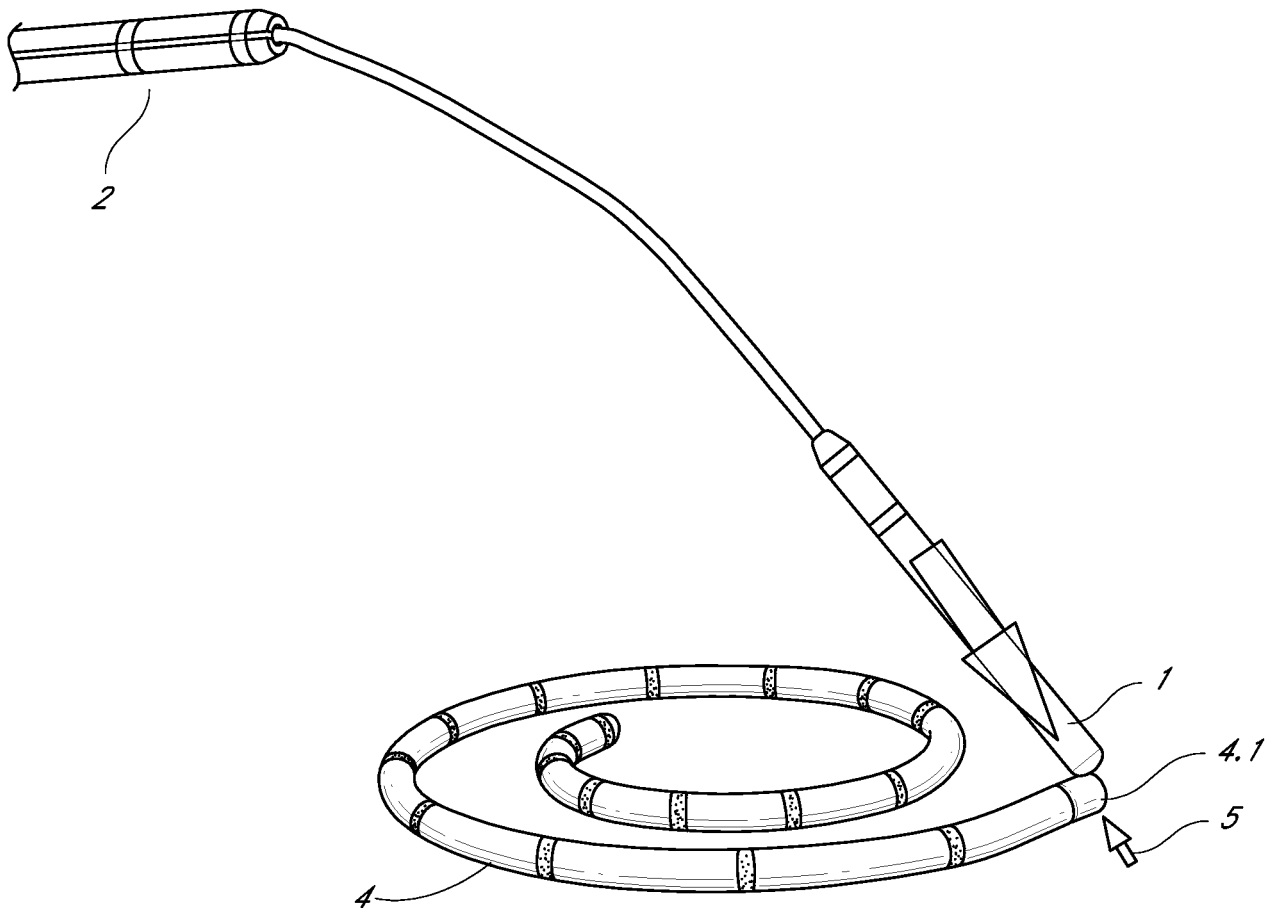

FIG. 3

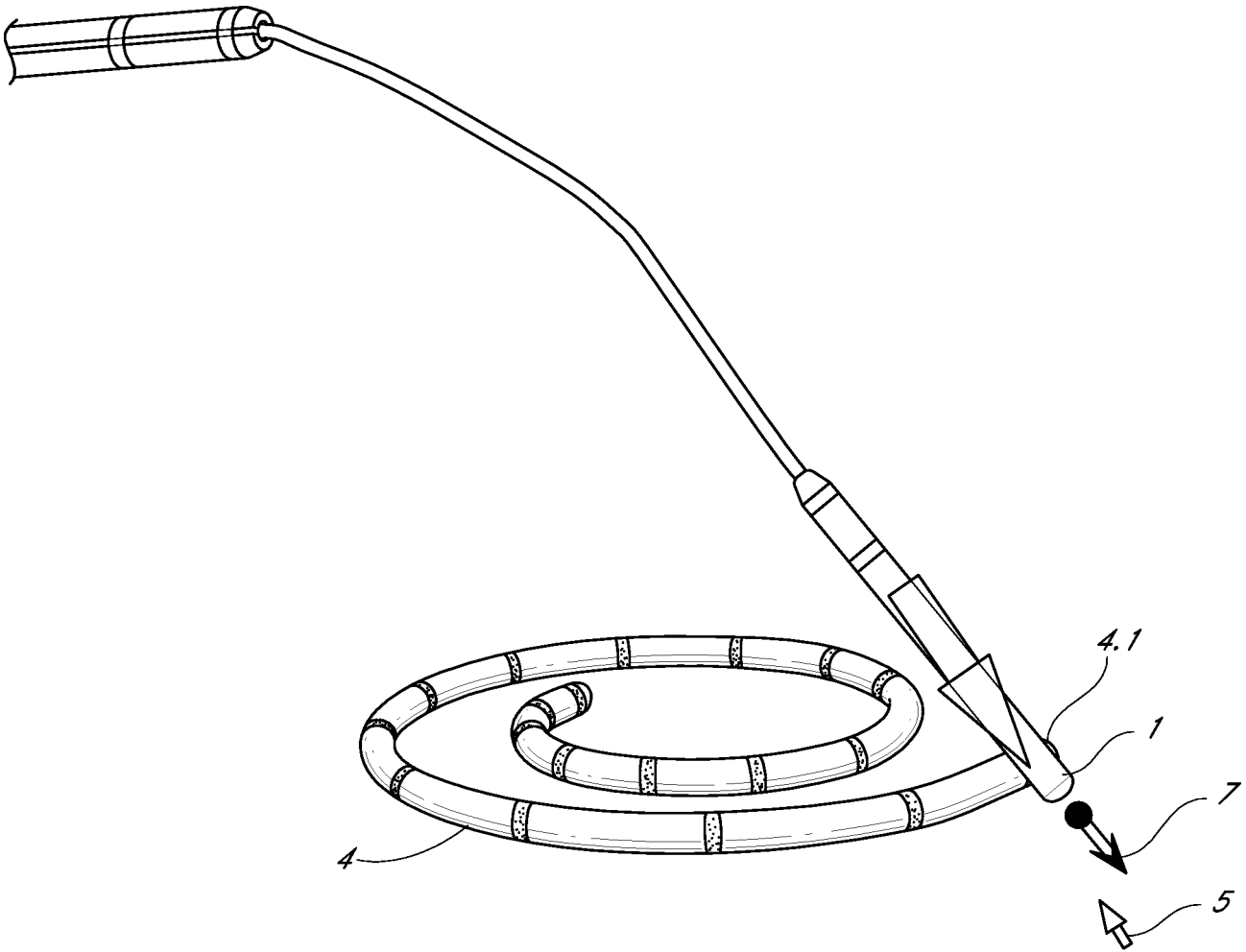

FIG. 4